

Medwell Journals
→ Scientific Research Publishing Company

ISSN : 1816-949x



Journal of
**Engineering and
Applied Sciences**

Medwell Journals
P.O. Box 114537, Dubai, UAE
medwelljournals@gmail.com
+971 50 134 7030



Journal of
**Engineering and
Applied Sciences**

Volume 10
No. 11 (2022)
ISSN 1927-0248

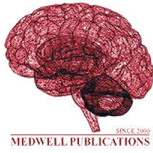

Search in Medwell

Search

[Home](#) [About Us](#) [For Authors](#) [For Subscriber](#) [Publication Ethics](#) [Journals](#) [Contact](#)

About Medwell Publications

Medwell Publications is a multidisciplinary academic publisher which aims to provide up-to-date and reliable source of research to the scientific community, as well as to promote the distribution of scientific research globally. The journals of Medwell Publications are peer reviewed, open access, and available in online and printed form.

Open access allows publishers and researchers to use necessary data applicable to their interests of study. It is possible to find latest research findings throughout the world free of charge. Readers are allowed to use, cite, download, and explore the literature in accordance with the law.

Medwell Publications was established in 2002; during this period more than 7000 scientists of various disciplines have published their researches. We support clients during the whole process of publishing, by allowing authors to focus mainly on their research. Our team provides proofreading review, ensuring the general requirements of manuscripts, novelty of topics, and the quality of research.

Medwell Publications is led by a team of international experts in the Editorial Board. All articles undergo a thorough evaluation process while following all ethical guidelines to maintain the highest publishing standards. Publication integrity is one of the principle responsibilities we take. The Medwell Team strictly review suitability, originality of manuscripts for publication. Our Editors maintain transparency of research; assess manuscript for scientific value; ensure that content is free from any manifestations of discrimination; evaluate information objectively without any commercial interests.

Our publications scope covers various disciplines related to the science, medicine, and technology. Moreover, because of the broad range of articles, journals are updated on the regular basis: monthly, bi monthly, quarterly a year.

The mission of Medwell Publications is to cooperate with the researchers, scientists of any disciplines to publish their articles in digital environment and make a contribution to the global science by providing open access publications.

Medwell Publications

[Privacy Policy](#) [Terms & Conditions](#)
[Contact us](#)

CONTACT DETAILS

✉ medwellonline@gmail.com
☎ +92 322 22 22 345

WE'RE SOCIAL



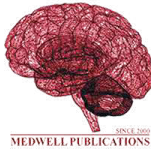

Search in Medwell

Search

[Home](#) [About Us](#) [For Authors](#) [For Subscriber](#) [Publication Ethics](#) [Journals](#) [Contact](#)

Dear Researchers

We are pleased to inform that MEDWELL Publications is now purchased by MAK Hill Publications.

It is to notify that the authors published previously their papers with Medwell Publications are secured and available with open access as it was before the Title of Journals with remain same with the same information of ISSN online, Print and aim and scope of journal will also be the same. After considering all ethical publication behaviors and polices we ensure that the authors information and data is secured. MAK Hill Welcome all researchers and scholars on board for publishing partnership. Our policies and guidelines are up to date as per current requirements of international standard for publication and COPE.

We invite authors for visiting our site kindly visit:

<https://makhillpublications.co/>

For any further assistance you can contact us on provided contact details we welcoming authors, researchers, reviewers and editors to partnership with MAK Hill Publications.

Regards

MAK Hill team



International Community

Open Invitation for authors world wide to share their true knowledge in the shape of descriptive literature with scientific world and researchers.



Open Access

Medwell Publication offering open access journals for researchers and scientists to explore latest research in unique way.



Rapid Publications

Time is Money, complete publication process in ideal time span suitable for authors, publications in peer reviewed journal with fullfill all quality measure.

Latest Research News

Patterns of Tuberculosis Infection in El-Obeid City, North Kordofan State, Sudan

Tuberculosis is at the top of health problems in the various regions of Sudan, where this disease is associated with poverty and poor environmental and health conditions. Therefore, it spreads among poor communities as well as the displaced. The present study aimed to study patterns

Gardener's itchy eye turns out to be maggot larvae infestation

Posted on Monday June 06, 2022

A 53-year-old man went to a French emergency room complaining of a persistently itchy eye. He told his medical team that earlier that day while gardening, he had "felt something enter his right eye"

Exacerbation of Autoimmune Hemolytic Anemia after COVID-19

Posted on Monday June 13, 2022

Complementary and Alternative Medicine (CAM) use for chronic dermatological conditions is common. However, such usage data in

of tuberculosis infection. A retrospective

Posted on Wednesday July 13, 2022

the South Indian population is lacking. The study aimed to investigate the frequency and types of CAM users among patients with chronic dermatological conditions in a tertiary care South



International Business Management

Dinh Tran Ngoc Huy

GSIM, International University of Japan, Niigata, Japan

It is the time to connect all our ideas about doing in business and managing it in the active world. In the context of Trump commerce war, this is the time to show your viewpoint on academic theory and practice applying in business:

[Read More](#)

MEDWELL PUBLICATIONS IS A HUB FOR

Scientists, Technologists, and Researchers

[View all Journals](#)

Medwell Publications

[Privacy Policy](#) [Terms & Conditions](#)

[Contact us](#)

CONTACT DETAILS

✉ medwellonline@gmail.com

☎ +92 322 22 22 345

WE'RE SOCIAL



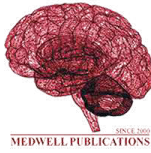

Journals By Subject

[Agricultural Sciences](#)[Animal Sciences](#)[Applied Sciences](#)[Business Sciences](#)[Earth Sciences](#)[Engineering](#)[Information Technology](#)[Medical Sciences](#)[Molecular Sciences](#)[Pharmacology](#)[Social Sciences](#)
[Home](#) / [Journals](#) / [Journal of Engineering and Applied Sciences](#)

Journal of Engineering and Applied Sciences (2022 Volume 17)

Number of issues per year: 24

ISSN: 1816-949x (Print)

ISSN: 1818-7803 (Online)

[In Press](#)[Current Issue](#)[Archive](#)[Editors](#)[Guide](#)

Aims & Scope

Journal of Engineering and Applied Sciences provides its' readers basic and transitional knowledge in engineering, technology and applied sciences. JEAS was established in 2006, and is led by a team of international experts in the Editorial Board. All articles undergo a thorough evaluation process while following all ethical guidelines to maintain the highest publishing standards. The journal is published twice a month. It is available in online and in printed format.

Subject areas suitable for publication include, but are not limited to the following fields:

- :: Applied Science
- :: Mathematics
- :: Electrical engineering
- :: Computer engineering
- :: Electronic engineering
- :: Optical engineering
- :: Power engineering
- :: Mechanical engineering
- :: Acoustical engineering
- :: Manufacturing engineering
- :: Thermal engineering
- :: Vehicle engineering
- :: Automotive engineering
- :: Aerospace engineering
- :: Naval architecture
- :: Agricultural engineering
- :: Bioprocess engineering
- :: Food engineering
- :: Aquaculture engineering
- :: Applied engineering
- :: Automation/Control systems/Robotics
- :: Computer-aided Drawing & Design (CADD)
- :: Construction
- :: Electronics
- :: General
- :: Graphics
- :: Manufacturing
- :: Nanotechnology
- :: Biological engineering
- :: Biomedical engineering
- :: Genetic engineering
- :: Biochemical engineering
- :: Biological organisms
- :: Tissue engineering
- :: Protein engineering
- :: Building services engineering
- :: Energy engineering

- :: Industrial engineering
- :: Manufacturing engineering
- :: Component engineering
- :: Systems engineering
- :: Construction engineering
- :: Textile Engineering
- :: Safety engineering
- :: Reliability engineering
- :: Mechatronics
- :: Nano engineering
- :: Nuclear engineering
- :: Petroleum engineering
- :: Chemical Engineering
- :: Water Resources Engineering
- :: Geotechnical Engineering
- :: Management
- :: Accounting

Abstracted/Indexed in

- :: Asian Digital Library
- :: Google Scholar
- :: ASCI-ACR
- :: EMBASE
- :: Chemical Abstracts Service (CAS)
- :: WorldCat
- :: JournalSeek
- :: HEC
- :: Zetoc Informing Research
- :: Journal Guide
- :: MIAR
- :: NDSL

Medwell Publications

[Privacy Policy](#) [Terms & Conditions](#)
[Contact us](#)

CONTACT DETAILS

✉ medwellonline@gmail.com
☎ +92 322 22 22 345

WE'RE SOCIAL



Journals by Subject

- [Agricultural Sciences](#)
- [Animal Sciences](#)
- [Applied Sciences](#)
- [Business Sciences](#)
- [Earth Sciences](#)
- [Engineering](#)
- [Information Technology](#)
- [Medical Sciences](#)
- [Molecular Sciences](#)
- [Pharmacology](#)
- [Social Sciences](#)

Journal of Engineering and Applied Sciences (2018 Volume 13)

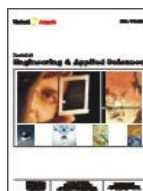

Number of issues per year: 24
ISSN : 1816-949x (Print)
ISSN : 1818-7803 (Online)

[CURRENT ISSUE](#) | [ARCHIVE](#) | [EDITORS](#) | [GUIDE TO AUTHORS](#) | [SUBMIT A MANUSCRIPT](#)

ARCHIVE >> Volume 13 Issue 1, 2018

[Shipper's Perceptions of Aviation Logistics Service Quality \(LSQ\) of Air Freight Provider](#)

Nor Aida Abdul Rahman, Mohammad Fakhruhnizam Mohammad, Suzari Abdul Rahim, Rohail Hassan, Md Fauzi Ahmad and Suhaila Abdul Kadir

[Validation of Object-Oriented Software GA Metric Selection Model using Domain Experts](#)

Abubakar Diwani, Abu Bakar Md Sultan, Hazura Zulzalil and Jamilah Din

[Taking Software Testing to the Cloud-Benefits and Guidelines](#)

Lim Chien Win, Soo Shi Tzuaan and Farah Farhana Mohd Nazri

[Study on the Processes of Energy Conservation and Efficient Energy Use in the Innovative Development Programs of Russian Companies](#)

A. Melnik and K. Ermolaevb

[Design and Implementation of Automatic Underwater Multi-target Detection based on RESAN](#)

R. Rajendr Prasad

[Stream Aquatic Reaping and Crop Fields Redeemable using Rain Drop Detection Sensor](#)

R. Rajendr Prasad

[Cost Effective of Ballast Water Management for Atlantic Coast](#)

K. Karthick

[A Frequency Recovery Effect by Operating Battery Energy Storage System in Transient State in the Power System](#)

Hyun-Chul Lee, Byoung-Jo Jung, Yong-Gi Roh and Hui-Bae Lee

[Secure Ranked Keyword Search Algorithm for Encrypted Cloud Data using Double Indexing Technique](#)

Payal V. Kale and Rashmi Welekar

[On Balanced Deployment of Dynamic Objects in Distributed Environments](#)

Lung Pin Chen and Hsin Ta Chiao

[The Relationships among Lean Production, Operational Performance and Financial Performance](#)

Piyachat Burawat

[Time Performance Evaluation for Batch Processing in Salesforce.com Cloud Computing](#)

Awfa Hasan Dakheel and Alaa Shawqi Jaber

[2D Symmetric 16x8 SRAM with Reset](#)

D. Khalandar Basha, Shashikanth Reddy and K. Aruna Manjusha

[The Development of a Eigenface Detection System](#)

Tae- Eun Kim

[A Study in Virtual Educational Training System for Police with Augmented Reality Technology](#)

O.H. Sei-youen



[Iris Controlled Wheel Chair in Real Time](#)

Kshama Chaudhary, Naveen Agarwal, Naveen Garg and Vikas Deep

[Study the Effect of the Particle Size of the Scattering Centers in Each of Linear and Non-Linear Optical Properties for the Laser Random Media](#)

Jassim M. Jassim, Yassin H. Khadim and Mithaq M. Mehdy Al-Sultani

[Electronic Properties Calculation of CO and NO Adsorbed on BN Nanolayer, using Density Function Theory DFT](#)

Abbas Hassan Abo Nasriya

[Enhancing Turbidity Removal using Electrocoagulation Method](#)

Mohammad Abid Muslim Altufaily and Zahraa Ahmed Abedalaama

[Ozone Production Based on Photovoltaic Source](#)

Waluyo , Deri Muhamad Nurendi, Syahrial and Nasrun Hariyanto

[Energy Efficiency of Combined Autonomous Energy Supply Systems Based on Ground Source Polygeneration Plants in the Conditions of the Extreme Continental Climate of Kazakhstan](#)

Vyacheslav Stoyak, Saule Kumyrbayeva, Madina Ibragimova and Alimzhan Apsemetov

[The Results of Theoretical Studies of the Vibrator Compensating Chamber of the Dispenser of Mineral Fertilizers](#)

Sayakhat Nukeshev, Indira Mamyrbayeva, Kairat Eskhozhin, Aigul Balabekova and Ziyada Zhaksylykova

[Mathematical Model for the Research of Systems with Massively Parallel Processing Based on Big Data](#)

Serbin Vassiliy, Moldagulova Aiman, Duisebekova Kulanda, Satybaldiyeva Ryskhan, Orazbekov Sayatbek, Tursynkulova Akbota, Alimzhanova Laura, Zhuanyshiev Ilyas, Rakhmetulayeva Sabina and Bektemyssova Gulnara

[The Preparation of Nano thin Films of Polyaniline/Carbon Nanotubes and Studying their Reaction to Some of the Organic Materials](#)

Mohammed Hadi Shinen, S.A.A. AlSaati, H.A. Laken and Fouad Z. Razoogi

[Study on the Characteristic of Air Flow of Shark Antennas for Each of the Configurations by using Simulated Flow Analysis](#)

Kye-Kwang Choi and Jae-Ung Cho

[Design and Structural Analysis of Steam Turbine](#)

K. Dinesh

[Competences and Commitments on Work Related Convictions of Software Professionals](#)

Makarand Upadhyaya, Hatem Mohamed EL-Shishini and Deepa Chavan

[Experimentation on Emission Analysis of a Compression Ignition Engine Run with Bio-diesel](#)

R. Sundara Raman, G. Sankara Narayanan, N. Manoharan and S. Sendilvelan

[Heavy Metals Residues in Soil and Vegetables from Agricultural Area in Wangkanai District, Kanchanaburi Province, Thailand](#)

Pantip Kayee, Sursuda Seksitkan and Kunnikar Pattharadechapaibul

[A Determination of Solar Heat Collection in Sepertine Copper and Rubber Pipe Embedded in Asphalt Pavement using Finite Element Method](#)

Mushtaq Ahmad, Zarina Binti Itam, Salmia Beddu, Firas Basim Ismail Alanimi and Shamini A/P Soanathan

[The Integrated of City's Identity and its Relationship to the Level of Citizen's Needs in Donggala City, Indonesia](#)

Amar Akbar Ali

[Analyzing the Factors Affecting the Soil Investigation Cost](#)

Hafeth I. Naji

[Phytochemistry and Antioxidant Activity of Essential Oils of Condiment and Spice Plants from South Western, Iran](#)

Abdollah Ghasemi Pirbalouti, Lyle Craker and Seyed Mohammad Alavi-Samani

[Decontamination of Hexavalent Chromium by Geo Chemical Fixation Method in a Hazardous Dump Site, Ranipet, Tamil Nadu, India](#)

T. Edwin D. Thangam, V. Nehru Kumar and Y. Anitha Vasline

[The Effect of Learning Model and the Type of Formative Assessment Toward the Natural Science Achievement after Controlling the Prior Knowledge Students](#)

Ni Ketut Rapi, Ketut Suma and I. Wayan Widiana

[Performance Evaluation of Tuple Timestamp Multiple Historical Relation Data Model](#)

Shailender Kumar

[Wireless Power Transmission Between Efficiency and Health Effects](#)

Ahmed Aizaldeen Abdullah

[Performance Enhancement of MPSK at High Data Rate](#)

Hadi Athab Hamed

[The Question of Study of the Formation Competence of the Students in the Pedagogical System](#)

Duisenova Marzhan Moldakasymovna and Dauletbekova Zhanat Turarbekovna

[Smart Technologies for Patients with Alzheimer's Disease: A Review](#)

Hana Tomaskova and Richard Cimler

[Revealing the Non-Muslim Kopitiams and the Awarded Halal Signage](#)

Abdul Mutalib Embong, Raja Ahmad Iskandar Raja Yaacob, Nur Arfah Abdul Sabian, Azelin Bt Mohamed Noor, Razita Mohamad and Abdul Hanif Lahmuddin

[A Study on Improvement of Device Removal Processes from ZigBee Network](#)

Jae-young Lee

[The Influence of Tool Path Strategies on Surface Roughness and Machining Time in the CNC Milling of UHMWPE](#)

W.D. Lestari, P.W. Anggoro, P.K. Fergjawan, R. Ismail, J. Jamari and A.P. Bayuseno

[Three-Dimensional CMOS Image Sensors Integrated with On-Chip Infrared Filters and Color Filters](#)

Ho-Pyo Hong and Myung Bok Lee

[An Analysis Study on Durability and Mechanical Characteristic of Notched Tensile Specimens by Material](#)

Jung-Ho Lee and Jae-Ung Cho

[Home](#) | [Journals](#) | [For Authors](#) | [For Subscribers](#) | [Privacy Policy](#) | [Terms and Conditions](#) | [Contact Us](#)

© Medwell Publishing 2018 All Rights Reserved



Search in Medwell

Search

Journals By Subject

- Agricultural Sciences
- Animal Sciences
- Applied Sciences
- Business Sciences
- Earth Sciences
- Engineering
- Information Technology
- Medical Sciences
- Molecular Sciences
- Pharmacology
- Social Sciences

[Home](#) / [Journals](#) / [Journal of Engineering and Applied Sciences](#) / [Editorial Board](#)



Journal of Engineering and Applied Sciences (2022 Volume 17)

Number of issues per year: 24

ISSN: 1816-949x (Print)

ISSN: 1818-7803 (Online)

In Press

Current Issue

Archive

Editors

Guide

Editorial Board

Director of Publications

Muhammad Kamran

Editorial Board Members

Dr. Dimitris Kanellopoulos	Greece
Ahmed A. Hamoud	Yemen
Dr Murat Karakus	Turkey
Dr Oleg Makarynsky	Australia
Dr ZEDIRA Hamma	Algeria
Dr. A.M.S. Hamouda	Qatar
Dr. Adel M. Alimi	Tunisia
Dr. Afaq Ahmad	Oman
Dr. Amir Nassirharand	Iran
Dr. Angelo Basile	Italy
Dr. Baowen Xu	China
Dr. Bensafi Abd El Hamid	Algeria
Dr. Bin Xu	China
Dr. Byung-Gyu Kim	Korea
Dr. Cesim Atas	Turkey
Dr. Chien-Ho Ko	Taiwan
Dr. Christopher J. Koroneos	Greece
Dr. Chunzhao Liu	China
Dr. Coskun Hamzacebi	Turkey
Dr. Daoud I. Zatari	France
Dr. Dipankar Pal	India
Dr. Elif Derya Ubeyli	Turkey
Dr. Ercan Kahya	Turkey
Dr. Fabian I. Ezema	Nigeria
Dr. Govindhan Dhanaraj	USA

Dr. Guibing Zhu	China
Dr. H-S Shen	China
Dr. Hai-Bin Duan	China
Dr. Haitao Liu	USA
Dr. Haiwen Liu	Germany
Dr. Hao Yi	China
Dr. H◊seyin Aksel Eren	Turkey
Dr. Isaac Elishakoff	USA
Dr. Isik Yilmaz	Turkey
Dr. Jadambaa Temuujin	Mongolia
Dr. Jasvir Singh	India
Dr. Ji-Huan He	China
Dr. Justin Zhan	USA
Dr. K.W. Chau	Hong Kong
Dr. Ling WANG	China
Dr. Lykourgos Magafas	Greece
Dr. MAHDI HOSSEINI	China
Dr. Maode Ma	Singapore
Dr. Marcin Marek Kamiński	Poland
Dr. Mark J. Kaiser	USA
Dr. Miklas Scholz	United Kingdom
Dr. Minggen Cui	China
Dr. Mohamad Y. Jaber	Canada
Dr. Mohamed Younes El Bouti	Morocco
Dr. Nam H. Tran	Australia
Dr. Oke Sunday Ayoola	Nigeria
Dr. Ozgur Kisi	Turkey
Dr. P. Predeep	India
Dr. Pavan Kumar	India
Dr. Qiang Ji	USA
Dr. Radka Vaníčková	Czech Republic
Dr. Sabah A. Abdul-Wahab Al-Sulaiman	Oman
Dr. Sabeha Barzan Farhod	Iraq
Dr. Shahram Ariafar	Norway
Dr. Siamak Hoseinzadeh	South Africa
Dr. Steven Sheng-Uei Guan	United Kingdom
Dr. Tariq Jamil	Oman
Dr. Ugur Ulusoy	Turkey
Dr. Yaser Dahman	Canada
Dr. Yong Hong Wu	Australia
Dr. Yugang YU	The Netherlands
Dr. Yunus BIÇEN	Turkey
Dr. Zhenya Yan	China
Dr. Zine Eddine Baarir	Algeria
Dr.N.S Marimuthu	India
Dr.V.Sivasubramanian	India
Ebaa A. Azooz	Iraq
Iman Isho Gorial	Iraq

Karwan Hama Faraj Jwamer	Iraq
Lubos Smutka	Czech Republic
Mansoor Maitah	Czech Republic
Oluwumi Adetan	Nigeria
Osama Basim Al-saffar	Iraq
Prof Dr. Rosziati Ibrahim	Malaysia
Prof. Ali Allahverdi	Kuwait
Prof. C. S. Bagewadi	India
Prof. Dr. Ahmed Masmoudi	Tunisia
Prof. J. M. Feliz Teixeira	Portugal
Prof. Jan Awrejcewicz	Poland
Prof. Jean Deprez	France
Prof. M. Jumah	Jordan
Prof. Magdy El-Tawil	Egypt
Prof. Milorad Bojic	Serbia
Prof. Onwaree Ingkatecha	Thailand
Prof. T. Sree Renga Raja	India
Prof. Yskandar Hamam	France
Prof. Jaime Cuauhtemoc Negrete	Mexico
Professor Dr. Ho Soon Min	Malaysia
Sajjad Sattai	Iran
Solomiia Fedushko	Ukraine

Medwell Publications

[Privacy Policy](#) [Terms & Conditions](#)
[Contact us](#)

CONTACT DETAILS

✉ medwellonline@gmail.com

☎ +92 322 22 22 345

WE'RE SOCIAL



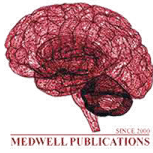

Search in Medwell

Search

Medwell Publications

Head Office:

23-25, Gulshan-e-Makkah, Sargodha Road, Faisalabad, Punjab, Pakistan
+92 322 6356054

Email:

medwellonline@gmail.com

Name

Email

Contact Number

Article No.

-- Select --

Comments OR Query

Send Message

Medwell Publications

[Privacy Policy](#) [Terms & Conditions](#)
[Contact us](#)

CONTACT DETAILS

medwellonline@gmail.com

+92 322 22 22 345

WE'RE SOCIAL



Journal of Engineering and Applied Sciences

Discontinued in Scopus as of 2019

COUNTRY

Pakistan



Universities and research
institutions in Pakistan

SUBJECT AREA AND CATEGORY

Engineering

└ Engineering (miscellaneous)

PUBLISHER

Medwell Journals

H-INDEX

29

PUBLICATION TYPE

Journals

ISSN

1816949X, 18187803

COVERAGE

2008-2019

SCOPE

Information not localized

Join the conversation about this journal

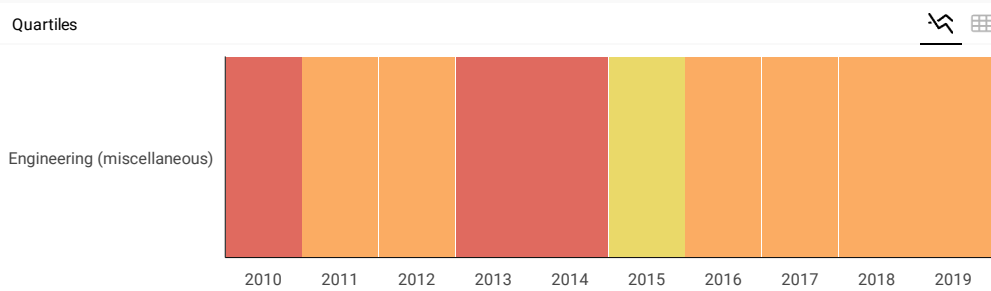

1
International Journal of Engineering and ARE
 ARE
60%
 similarity

2
International Journal of Advanced Science and AUS
 AUS
57%
 similarity

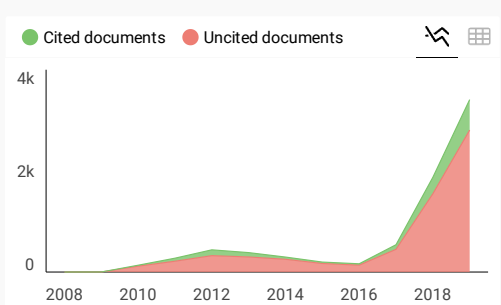
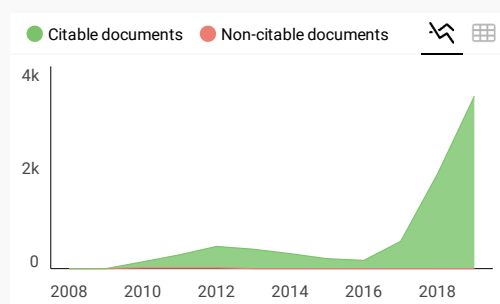
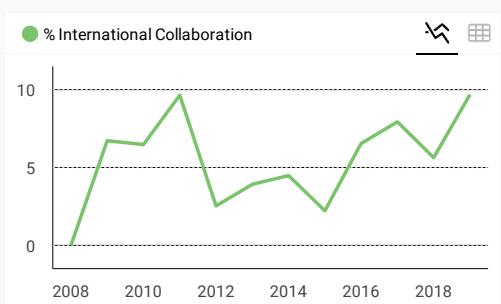
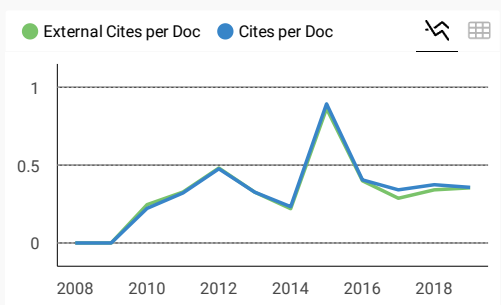
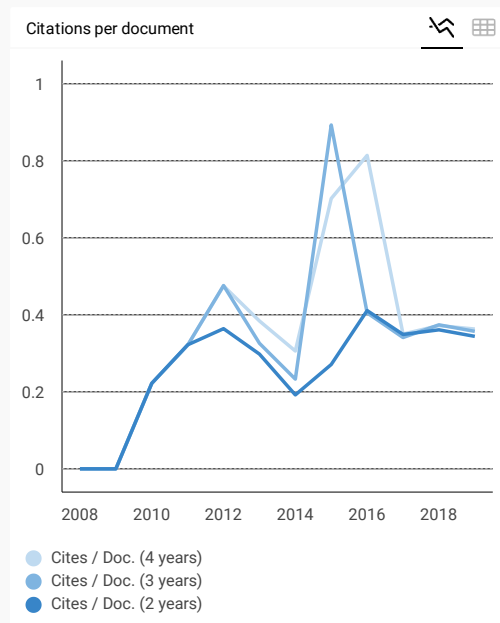
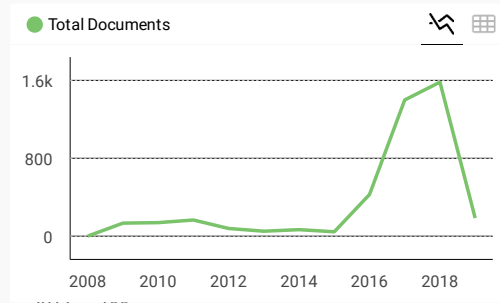
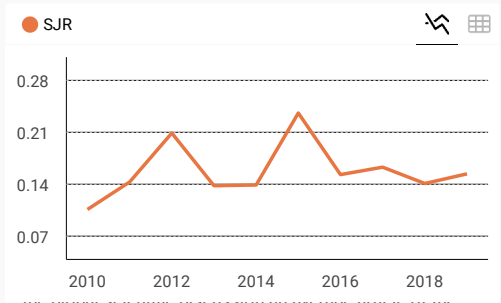

Journal of Engineering and Applied Sciences ← Show this widget in your own website

Not yet assigned quartile

Just copy the code below and paste within your html code:

SJR 2021
 0
 powered by scimagojr.com

```
<a href="https://www.scimaç
```

SCImago Graphica

Explore, visually communicate and make sense of data with our **new data visualization tool.**



Ahmed Fadhil 2 years ago

Hello

May I know in which month volume 13 issue 10 (2018) of the journal (Journal of Engineering and Applied Sciences) was published?

Best regards

← reply



Melanie Ortiz 2 years ago

SCImago Team

Dear Ahmed, thank you very much for your comment. Unfortunately, we cannot help you with your request, we suggest you contact the journal's editorial staff so they could inform you more deeply. Best Regards, SCImago Team



Ali N. Hamoodi 2 years ago

Dear Sir,

Please can you send to me the cite score until 2018 of JEAS

Thanks

Regards

← reply



Melanie Ortiz 2 years ago

SCImago Team

Dear Ali, thank you very much for your comment.

We suggest you consult the Scopus database directly to see the CiteScore.

Best Regards, SCImago Team



Akbar Tizfahm 2 years ago

Hi Dear

We submitted our paper 7 months ago and it is still in the under review stage. How long does it take for them to respond?

Best regards

← reply



Melanie Ortiz 2 years ago

SCImago Team

Dear Akbar,

Thank you for contacting us. Please see comments below.

Best Regards, SCImago Team

A

ajay kumar 2 years ago

why this journal out of scopus? this is good journal scopus must try to reconsider this journal.

← reply

**Melanie Ortiz** 2 years ago

SCImago Team

Dear Ajay,
thank you very much for your comment, unfortunately we cannot help you with your request. We suggest you contact Scopus support:
https://service.elsevier.com/app/answers/detail/a_id/14883/kw/scimago/supporthub/scopus/
Best Regards, SCImago Team

A

Ali Mozaffari 2 years ago

Hi Dear

We have been submitting our paper for almost 6 months and no response has been received from the journal. Please advise how to follow up?

Best regards

← reply

**Melanie Ortiz** 2 years ago

SCImago Team

Dear Ali,
thank you for contacting us. Please see comments below.
Best Regards, SCImago Team

**Prince Nweke** 2 years ago

Medwell Publications (Journal of Engineering and Applied Sciences) is a wonderful research impact factor journal, very reliable, dedicated, effective, cost friendly and highly applauded. I appreciate your professionalism and being time conscious. Bravo! Assalamu Alaikum! Thank you!!!
Prince Nweke O.
University of Nigeria, Nsukka

← reply

J

jhon 2 years ago

Scopus must review the decision i am surprised that how this journal can be discontinue as it was working great. too much disappointed i will strongly recommend this journal

A

Aijay 3 years ago

Hello,
I have a paper to publish but i dont know how to go about it. Can I get assistance here.

← reply

M

Marieah 2 years ago

please submit your article after taking these steps, please click
<http://www.medwelljournals.com/ams> register yourself first, user ID and Password than submit your article online



Melanie Ortiz 3 years ago

SCImago Team

Dear Aijay, thank you very much for your comment, we suggest you look for author's instructions/submission guidelines in the journal's website. Best Regards, SCImago Team



MARAL ANWER MUSTAFA 3 years ago

Hi,

I have published a paper almost 14 months ago in this journal.
We want to withdraw the research from the journal.
Note that the article is published in your journal.
Journal of Engineering and Applied Sciences 14 (Special Issue 8): 10311-10317, 2019
article title:
(In the Way of having an Optimum Wireless Ad-Hoc Sensor Networks:
Analysis of Deploying Homogeneous and Inhomogeneous Nodes)

← reply



Melanie Ortiz 3 years ago

SCImago Team

Dear Maral,
thank you for contacting us.
We are sorry to tell you that SCImago Journal & Country Rank is not a journal. SJR is a portal with scientometric indicators of journals indexed in Elsevier/Scopus.
Unfortunately, we cannot help you with your request, we suggest you contact the journal's editorial staff, so they could inform you more deeply.
Best Regards, SCImago Team



MUHTADI 3 years ago

dear ALi.

how many pages maximum allowed ?

← reply



MS 3 years ago

Dear SCImago Team, this journal is out of scopus now but still in SJR. so what relation between scopus and SJR. Best Regards

← reply



Melanie Ortiz 3 years ago

SCImago Team

Dear Sir/Madam,

Thank you for contacting us. Our data come from Scopus, they annually send us an update of the data. This update is sent to us around April / May every year. However, we always suggest our users to consult the Scopus database directly. Keep in mind that the SJR is a static image (the update is made one time per year) of a database (Scopus) which is changing every day.
Best Regards, SCImago Team



rita sundari 3 years ago

I'm interested in paper publication.
If I have a paper, how to submit the paper to this journal ?

Thanks.

Sincerely,

Dr Rita Sundari

← reply



Muhammad Kamran 3 years ago

please submit your article after taking these steps, please click
<http://www.medwelljournals.com/ams> register yourself first, user ID and Password than
submit your article online



Marieah 3 years ago

Kindly submit the paper on site www.medwelljournals.com/ams



Melanie Ortiz 3 years ago

SCImago Team

Dear Marieah, thanks for your participation! Best Regards, SCImago Team



Mohammed Sabah Ali 3 years ago

This journal out of scopus



Melanie Ortiz 3 years ago

SCImago Team

Thanks for your participation! Best Regards, SCImago Team



ahmed 3 years ago

dont submit your paper because this journal is not in scopus anymore



Melanie Ortiz 3 years ago

SCImago Team

Dear Rita, thank you very much for your comment, we suggest you to look for author's
instructions/submission guidelines in the journal's website or click on "How to Publish"
just above. Best Regards, SCImago Team



Ahmed 3 years ago

More than one year and my article not getting in Scopus and today I check on the Scopus database
that the journal is not in scoops any more , you always keep saying soon your paper will be in
scoops

They are a great cheater !!!!!!!

← reply



Marieah 3 years ago

Dear Ahmed this journal was discontinue by Scopus in the mid of 2019 after the month of
August kindly check the details again carefully.



Melanie Ortiz 3 years ago

SCImago Team

Dear Ahmed,
thank you for contacting us.
Sorry to tell you that SCImago Journal & Country Rank is not a journal. SJR is a portal with scientometric indicators of journals indexed in Elsevier/Scopus.
Unfortunately, we cannot help you with your request, we suggest you to visit contact the journal's editorial staff , so they could inform you more deeply. We also suggest you to contact Scopus
https://service.elsevier.com/app/answers/detail/a_id/14883/kw/scimago/supporthub/scopus/ for this requirement.

Best Regards, SCImago Team



Aruna 3 years ago

Is this journal scopus indexed at present

← reply



Ahmed 3 years ago

Not in Scopus any more you can check from Scopus database



Melanie Ortiz 3 years ago

SCImago Team

Dear Ahmed, thanks for your participation! Best Regards, SCImago Team



Melanie Ortiz 3 years ago

SCImago Team

Dear Aruna, thank you very much for your comment, unfortunately we cannot help you with your request. We suggest you consult the Scopus database directly. Remember that the SJR is a static image of a database (Scopus) which is changing every day. Best regards, SCImago Team



Samah 4 years ago

Hi;
I got an acceptance letter before one month. After I finish everything that related to journal policy. My question "How long the manuscript needs to publish in this journal as well as uploading on the Scopus database?"

← reply



Dr. Farah 4 years ago

Hi Elena
I've just to check if there is any renew for the scopus database now after January 2019) to check if some journals leave the database in this year

Best wishes

← reply



Lulu 4 years ago

If any Query regarding above Journal, Please contact Whatsapp No.91-81898 86138

S

Semin 4 years ago

Dear JEAS,

In year of 2016 we have submit 3 manuscript with author Semin et al. to publish in JEAS. We have revised and paid the processing cost clear. But, until now just 1 paper published in Nov 2017. Unfortunately, this published paper is not indexed in scopus until now.

With this case, we have contacted the editor via website but no response.

If you do not have publish and index in Scopus of our paper, please comeback our money for 3 paper and withdraw 1 paper from your JEAS website in Nov. 2017.

Regards
Author

← reply



Elena Corera 4 years ago

SCImago Team

Dear Semin,

sorry, but we cannot help you, you should contact Journal of Engineering and Applied Sciences, you are contacting SCImago Journal and Country Rank.

We hope you find your answer.

Best regards,
SCImago Team

N

Nada 4 years ago

I sent by email i will pay the fee and its 600\$ and i some researchers pay 450\$ why different in fees

← reply

A

Aram 4 years ago

Dear sir,

How can I check my acceptance paper for publishing?

← reply



Elena Corera 4 years ago

SCImago Team

Please, contact Journal of Engineering and Applied Sciences, you are contacting Scimago Journal and Country Rank.

Best,
SCImago Team

N

Nguyen Phuoc Minh 4 years ago

Dear Editor - Journal of Engineering and Applied Sciences,

- Your email on May 25th said that my articles will be published in volume 13, issue 17.
- Your email on October 29th mentioned that my articles will be published in volume 13, issue 23.
- However today I see the issue 23 on your website but I don't see my articles:

36423-JEAS

36425-JEAS

Perhaps you forget my 2 articles??? Or you cheat me??? I so worry about your promise because I paid the publication fee from March 2018.

Would you please let me know exactly the time of publication for following articles: 36423-JEAS,

36425-JEAS? Please remember your emails in the attached files! I want you clarify with me if you can publish my articles on issue 23 or not?

Regards,

← reply

 **John Wick** 4 years ago

The same situation here, finding journals indexed in Scopus give me probably assurance, but not in this case, after payment they don't answer anymore. I am thinking to re-send the paper else where since this is happening to people and no publication happened yet.



Elena Corera 4 years ago

SCImago Team

Thank you for your participation!



Elena Corera 4 years ago

SCImago Team

Dear Nguyen Phuoc,

we are so sorry, but we cannot help you. Please, contact Journal of Engineering and Applied Sciences, you are contacting Scimago Journal and Country Rank.

Best,
SCImago Team

 **Navid** 4 years ago

Dear Madam/Sir

I couldn't find the journal, Journal of Engineering and Applied Sciences, in Scopus database. highly appreciated if guide me regarding the matter.

Regard,
Navid

← reply

 **Tem** 4 years ago

Is this journal a legitimate one? Is it currently listed in Scopus?
The comments above make it hard to do business with.

Would you please give comment on the above questions.

← reply

 **Mushtaq A.K. Shiker** 4 years ago

Hi every one, I ask about the time of publishing my paper with title ((A modified Technique for Solving Unconstrained Optimization)), I've got (Acceptance letter on 20 May 2018, you said that it will be publish on November 2018 , to date it has not been published, Please I need it to be publish as soon as possible, my university want it to be published.

(Note : This is the third letter that I send to you about this publishing, I've got no response about the first two letters, so please give me response about this letter).

yours sincerely
Mushtaq A.K. Shiker

← reply

M

Mais 4 years ago

Hi,
I tried to submit a manuscript and after one day, I received an email that tells me that my paper has not been uploaded on the server machine successfully and the paper cannot progress to peer review and I was asked for sending the complete article with a cover letter in MSWord format via E-MAIL and after I sent it there was no response yet

← reply

D

Dr. Julius Otutu Oseji 4 years ago

WANT TO FIND OUT IF MY ARTICLE TITLED "GEOELECTRIC ASSESSMENT OF GROUND WATER PROSPECTS AND VULNERABILITY OF OVERBURDENED AQUIFER IN OLEH DELTA STATE, NIGERIA" WAS ACCEPTED FOR PUBLICATION WITHOUT PAPER ID NUMBER AND NO DIRECT PAYMENT INVOICE FROM Journal of Engineering and Applied Sciences. INSTEAD IT WAS TO A PRIVATE ACCOUNT. THIS LIMITS MY PAYMENT.

← reply

I

Itimad Azzawi 4 years ago

Hi

Could you please inform me if you have an account in scopus or not? because i have searched by your ISSN number and gave me 0 results?

Best Regards

← reply



Elena Corera 4 years ago

SCImago Team

Dear Itmad,

thank you for your request, all the journals included in SJR are indexed in Scopus. Elsevier / Scopus is our data provider.

Best Regards,
SCImago Team

I

Irina 4 years ago

I want to publish my paper

← reply



Elena Corera 4 years ago

SCImago Team

Dear Irina,

thank you very much for your comment, unfortunately we cannot help you with your request. We suggest you look for author's instructions in journal's website <https://www.medwelljournals.com/guidetoauthor.php?jid=1816-949x>

Best Regards,
SCImago Team

W

wafaa 4 years ago

Dear sir

Regarding my paper "speed control of induction motor using fuzzy logic control", manuscript number 37909. I have sent the fees (450\$) on 9-9-2018 but no reply was sent to me as weather you have received the money, when my paper will be published. I need an answer as soon as possible please.

Please reply through my email (wafaa.a.abdullah@gmail.com)

Thanks

← reply

H

Hiba 4 years ago

Dear Wafaa, Have you got a reply from the journal? ,
did they publish your paper? or did they tell you when they are going to publish it?



Elena Corera 4 years ago

SCImago Team

Dear Wafaa,
thank you very much for your comment. Unfortunately, we cannot help you with your request, we suggest you contact journal's editorial staff so they could inform you more deeply.
Best Regards,
SCImago Team

L

luaay 4 years ago

I want published my paper

← reply

D

Dr. Mohsin Abdullah Al-Shammari 4 years ago

I have submit my manuscript 9 months ago and I have payed the fee of publication and then they sent me the final acceptance letter. Since that time they procrastinating with me about the date of publication.since more than two months they told me that my article will be online with 15 days and no action. four days ago the sent me a final PDF to check the final mirror then I answer them that it is OK and also no answer. I am wondering what is the problem with them.

Note: This was happened with my colleagues in my department(more than four professors)

← reply



Elena Corera 4 years ago

SCImago Team

Dear Dr. Mohsin,
thank you very much for your comment. Unfortunately, we cannot help you with your request, we suggest you contact journal's editorial staff so they could inform you more deeply.
Best Regards,
SCImago Team

K

karolina 4 years ago

we had been submit our manuscript almost 2 years ago,

first time when i submit, a reviewer seems like make spams everyday to my email for complete as soon as possible payment, he said our paper will publish be publish 6 month, after we pay and sent "proof of payment", i dont know why, they are very slow responds almost 1 month, after that we tried to contact sent to email several time, and they only answer "your payment confirm", till now its

not publish yet.

i am not recommended for your all submit your article in this journal, they are just want your money

Regards

Karolina

← reply

Z

Zaid Al-Tameemi 4 years ago

Dear Dr

I received a acceptance letter for my manuscript

A comparative study of DTC-SVM and FOC-SVM techniques of PMSM motor

4 months ago but it hasn't been published right now

Regards

← reply

L

Lê Đức Thuận 4 years ago

I want to ask: Has your article been published in Journal of Engineering and Applied Sciences yet?

M

Mustafa taha 4 years ago

i submit a manuscript and i need to know review process time

please tell me the period between submit and get acceptance

thanks

M

Mojtaba Harati 4 years ago

Hi,

I have published a paper in this journal. I should say that the DOI they assigned to my paper doesn't work properly. I have said this problem to the authorities of this journal several times!!!!

They do not respond to me right now, and in this case, I do like to inform you that they are ignoring my request to resolve this problem!!!

Title of the paper:

An Investigation on the Effect of the Near-Fault Earthquakes on the Seismic Behavior of RC Moment Resisting Frames (MRFs) Designed Based on Iranian Seismic Code (Standard No. 2800)

authors: Mojtaba Harati , Ahmad Hojjati Sabet and Ataollah Hajati Modaraei

The DOI that doesn't work: 10.3923/jeasci.2016.274.283

Best regards,
Mojtaba Harati

← reply

R

Raheela 3 years ago

I already checked your article DOI but its properly running in medwell site kindly again check. I think you may have misunderstood something.....



Elena Corera 4 years ago

SCImago Team

Thanks for the info!



ali abdulhassan abbas 4 years ago

The publishing process takes a very long time. May reach up to a full year

← reply



Elena Corera 4 years ago

SCImago Team

Dear Ali, we suggest you locate the author's instructions on the journal's website. Best Regards, SCImago Team

Leave a comment

Name

Email

(will not be published)

I'm not a robot



reCAPTCHA
Privacy - Terms

Submit

The users of Scimago Journal & Country Rank have the possibility to dialogue through comments linked to a specific journal. The purpose is to have a forum in which general doubts about the processes of publication in the journal, experiences and other issues derived from the publication of papers are resolved. For topics on particular articles, maintain the dialogue through the usual channels with your editor.

Developed by:



Powered by:



Follow us on @ScimagoJR

Scimago Lab, Copyright 2007-2022. Data Source: Scopus®

EST MODUS IN REBUS

Horatio (Satire 1,1,106)



Source details

Journal of Engineering and Applied Sciences

Scopus coverage years: from 2008 to 2019

(coverage discontinued in Scopus)

Publisher: Medwell

ISSN: 1816-949X E-ISSN: 1818-7803

Subject area: Engineering: General Engineering

Source type: Journal

[View all documents >](#)

[Set document alert](#)

[Save to source list](#)

Check whether you can access Scopus remotely through your institution

[Maybe later](#) [Check access](#)

0.154

SNIP 2021
0.357

[CiteScore](#) | [CiteScore rank & trend](#) | [Scopus content coverage](#)

i Improved CiteScore methodology

CiteScore 2017 counts the citations received in 2014-2017 to articles, reviews, conference papers, book chapters and data papers published in 2014-2017, and divides this by the number of publications published in 2014-2017. [Learn more >](#)

CiteScore **2017**

$$0.2 = \frac{282 \text{ Citations } 2014 - 2017}{1,685 \text{ Documents } 2014 - 2017}$$

Calculated on 01 May, 2018

CiteScore rank 2017

Category	Rank	Percentile
Engineering		
General Engineering	#245/276	11th

[View CiteScore methodology >](#) [CiteScore FAQ >](#) [Add CiteScore to your site >](#)

About Scopus

- [What is Scopus](#)
- [Content coverage](#)
- [Scopus blog](#)
- [Scopus API](#)
- [Privacy matters](#)

Language

- [日本語版を表示する](#)
- [查看简体中文版本](#)
- [查看繁體中文版本](#)
- [Просмотр версии на русском языке](#)

Customer Service

- [Help](#)
- [Tutorials](#)
- [Contact us](#)

ELSEVIER

[Terms and conditions >](#) [Privacy policy >](#)

Copyright © Elsevier B.V. All rights reserved. Scopus® is a registered trademark of Elsevier B.V.

We use cookies to help provide and enhance our service and tailor content. By continuing, you agree to the [use of cookies >](#).



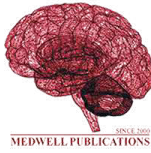

Related Links

[Abstract](#)

[Fulltext PDF](#)

[References](#)

Journals By Subject

[Agricultural Sciences](#)

[Animal Sciences](#)

[Applied Sciences](#)

[Business Sciences](#)

[Earth Sciences](#)

[Engineering](#)

[Information Technology](#)

[Medical Sciences](#)

[Molecular Sciences](#)

[Pharmacology](#)

[Social Sciences](#)

[Home](#) / [Journals](#) / [Journal of Engineering and Applied Sciences](#) / [Volume 13 Issue 1, 2018](#) / [Abstract](#)

Journal of Engineering and Applied Sciences

Year: 2018 | Volume: 13 | Issue: 1 | Page No. 105 - 118

DOI: [10.36478/jeasci.2018.105.118](https://doi.org/10.36478/jeasci.2018.105.118)

[Download PDF](#)

[References](#)

[Abstract](#)

Ozone Production Based on Photovoltaic Source

Authors : [Waluyo](#) , [Deri Muhamad Nurendi](#), [Syahrial](#) and [Nasrun Hariyanto](#)

Abstract: Ozone has been studied for various applications. Nevertheless, it is still rare that involves photovoltaic source. The research was to make designing, implementing, wave form measuring and testing the ozone generation based on solar power generation with dc-dc converter. The corona discharge current waveforms were investigated due to dc voltages. The relations among the oxygen flows, voltage levels and oxygen debits to the ozone product were also investigated. Both voltage and discharge current waveforms were measured by using a storage oscilloscope and transferred to a computer. The discharge currents were occurred in around every 72.6 μ sec intermittently. It was flowed 3 and 5 L/min of oxygen. It was yielded the greatest produced ozone in the third stage of voltage, 7.047 V, 5 L/min of oxygen debit and at minute of 50 that was 0.0323 mgO₃/L.

How to cite this article:

Waluyo , Deri Muhamad Nurendi, Syahrial and Nasrun Hariyanto, 2018. Ozone Production Based on Photovoltaic Source. *Journal of Engineering and Applied Sciences*, 13: 105-118.

DOI: [10.36478/jeasci.2018.105.118](https://doi.org/10.36478/jeasci.2018.105.118)

URL: <https://medwelljournals.com/abstract/?doi=jeasci.2018.105.118>

Medwell Publications

[Privacy Policy](#) [Terms & Conditions](#)
[Contact us](#)

CONTACT DETAILS

✉ medwellonline@gmail.com

☎ +92 322 22 22 345

WE'RE SOCIAL



Related Links

[Abstract](#)
[Fulltext PDF](#)
[References](#)

Journal of Engineering and Applied Sciences
Year: 2018 | Volume: 13 | Issue: 1 | Page No.: 105-118
DOI: 10.3923/jeasci.2018.105.118

Ozone Production Based on Photovoltaic Source

[Waluyo](#) , [Deri Muhamad Nurendi](#) , [Syahrial](#) and [Nasrun Hariyanto](#)

Journals by Subject

[Agricultural Sciences](#)
[Animal Sciences](#)
[Applied Sciences](#)
[Business Sciences](#)
[Earth Sciences](#)
[Engineering](#)
[Information Technology](#)
[Medical Sciences](#)
[Molecular Sciences](#)
[Pharmacology](#)
[Social Sciences](#)

Abstract: Ozone has been studied for various applications. Nevertheless, it is still rare that involves photovoltaic source. The research was to make designing, implementing, wave form measuring and testing the ozone generation based on solar power generation with dc-dc converter. The corona discharge current waveforms were investigated due to dc voltages. The relations among the oxygen flows, voltage levels and oxygen debits to the ozone product were also investigated. Both voltage and discharge current waveforms were measured by using a storage oscilloscope and transferred to a computer. The discharge currents were occurred in around every 72.6 μ sec intermittently. It was flowed 3 and 5 L/min of oxygen. It was yielded the greatest produced ozone in the third stage of voltage, 7.047 V, 5 L/min of oxygen debit and at minute of 50 that was 0.0323 mgO₃/L.

How to cite this article:

Waluyo , Deri Muhamad Nurendi, Syahrial and Nasrun Hariyanto, 2018. Ozone Production Based on Photovoltaic Source. *Journal of Engineering and Applied Sciences*, 13: 105-118.

DOI: [10.3923/jeasci.2018.105.118](https://doi.org/10.3923/jeasci.2018.105.118)

URL: <http://medwelljournals.com/abstract/?doi=jeasci.2018.105.118>

Ozone Production Based on Photovoltaic Source

Waluyo, Deri Muhamad Nurendi, Syahrial and Nasrun Hariyanto
Department of Electrical Engineering, Institut Teknologi Nasional Bandung (ITENAS),
Jalan PHH Mustafa No. 23, 40124 Bandung, Indonesia

Abstract: Ozone has been studied for various applications. Nevertheless, it is still rare that involves photovoltaic source. The research was to make designing, implementing, wave form measuring and testing the ozone generation based on solar power generation with dc-dc converter. The corona discharge current waveforms were investigated due to dc voltages. The relations among the oxygen flows, voltage levels and oxygen debits to the ozone product were also investigated. Both voltage and discharge current waveforms were measured by using a storage oscilloscope and transferred to a computer. The discharge currents were occurred in around every 72.6 μsec intermittently. It was flowed 3 and 5 L/min of oxygen. It was yielded the greatest produced ozone in the third stage of voltage, 7.047 V, 5 L/min of oxygen debit and at minute of 50 that was 0.0323 mgO_3/L .

Key words: Corona, dc-dc power conversion, oxygen, ozone, solar power generation, generation

INTRODUCTION

Ozone has been currently studied for various applications such as water treatment, domestic and industrial effluent treatment, medicine dentistry, veterinary medicine, agriculture, disinfectant of environment and food preservation. An improvement in its generation by ozone generator system is fundamental. Ozone can be produced in three ways: by electrolysis, Ultra Violet (UV) and corona effect (Schiavon *et al.*, 2012). Ozone is the triatomic state of oxygen that is a molecule comprising of three oxygen atoms. It is a relatively unstable and reactive gas (Smith, 2016).

Ozone is one of the most powerful chemical oxidizers and has many applications in industry. However, its use in industry as an oxidizing agent has been limited by the relatively low conversion efficiency of the ozone generator (Izeki, 1983). Despite, the small amount of generated ozone, there is enough to cause a variety of interesting oxidations (Mattson *et al.*, 2007).

Ozone is negative impacts, such as strongly contributes to aging on polymeric and silicone rubber materials (Ma *et al.*, 2010, 2011). Nevertheless, the ozone or corona discharge has positive impact, mainly for precipitation by Mizuno (2000) and Castle *et al.* (1969). Ozone is a by-product of corona discharge. Corona is observed in any forms including glows and haloes, spots, brushes and streamers. The potential at which corona is found to originate is called corona threshold voltage. Above this voltage, there is a limited region in which current increases proportionately with voltage

called the Ohm's law regime. After this region, the current increases more rapidly, leading to the complete breakdown and arcing or sparking at a point called the breakdown potential. Corona discharge is highly dependant on geometry. Electric field intensity is higher around a surface of charged conductor with higher curvature or lower radii of curvature. When the electric field increases, it influences the atomic orbital and may cause atoms or molecules to polarize or liberate electrons. The maximum electric field that a dielectric material can withstand without conduction is known as a dielectric strength (Panicker *et al.*, 2003; Loeb, 1965).

Ozone is manufactured in the corona discharge by drawing in air which is composed of 20% oxygen. This causes the oxygen molecules to dissociate and reassemble as ozone (LLC., 2015). The streamer type coronas used for ozone generation, generally use air or oxygen filled short gaps where one of the electrodes is covered with an insulating layer in order to prevent streamer-arc transition (Goldman *et al.*, 1985). Electrically, ozone can be generated by breaking the oxygen molecules in a dielectric barrier discharge chamber. The important property of the dielectric barrier discharge is the creation of cold non-equilibrium plasma at atmospheric pressure condition. In the chamber, a high voltage is applied between two electrodes, one of which is covered with dielectric. Oxygen is forced to flow in a space between the electrodes, called discharge gap. If the electric field is sufficiently high, it breaks the oxygen molecules into its atoms, the latter then combines with other oxygen molecules to ozone form. Excessive concentrations of

ozone at the ground level have adverse respiratory effects in humans (Ketkaew, 2007; Seinfeld and Pandis, 1998).

Some characteristics, modeling, effects and harmonics on ozone or corona discharge have been investigated (Patil and Vijayan, 2010; Szczepanski *et al.*, 2017; Pontiga *et al.*, 2001; Ohkubo *et al.*, 1990; Boonseng *et al.*, 2000). Gaseous ozone is toxic, e.g., the OSHA permissible exposure limit in air is only 0.1 ppm for an 8 h exposure. This concentration can be achieved by aqueous ozone concentrations of 0.018 ppm in pools and 0.011 ppm in spas. The limit for as shorter exposure, 10 min is 0.2 ppm (Wojtowicz, 2001). Ozone is used in industry as an oxidizing agent has been limited by the relatively low conversion efficiency of the ozone generator. For example, typical commercial ozone generators utilize about 5% of the input power in ozone production (Izeki, 1983). The temperature could influence the productivity of ozone. The relationship of temperature and ozone generating efficiency could be shown in mathematic polynomial equation (Sathalalai and Khan-ngern, 2009). It was be told the history of medical ozone and its other applications (Pressman, 2001).

The electric field intensity could be used as a type of ozone generator (Charlansut *et al.*, 2010). The generated ozone concentration was very dependent upon the value of pulse forming capacitance and ozone generator capacitance and corona tip-to-tip distance of the discharge electrode (Moon, 1992). Ozone could be generated or produced by various methods such as DC, pulsed and negative wire-to-cylinder corona discharges (Pontiga *et al.*, 2007; Chalmers *et al.*, 1996; Yanallah *et al.*, 2008), gas discharge (Samaranayake *et al.*, 2001), streamer corona (Fukawa *et al.*, 2008; Vijayan and Patil, 2011) and high frequency (Udhayakumar *et al.*, 2016). Another proposed of ozone generator using a phase-shift PWM full bridge inverter as a power supply. It offering high voltage and high frequency is capable of generating ozone (Hothongkham and Kinnares, 2009). A high frequency plasma generator experimental model was designed and built to study the behavior of the corona discharge at MHz frequencies and using inverter (Tudoran, 2011; Tsai and Ke, 2009). The L-C resonant

circuit-based power supply used in ozone generation has been also investigated without a transformer (Amjad *et al.*, 2012, 2013). A plasma generator composed of high frequency, high voltage transformer, discharging electrodes and zero voltage switching resonant converter has been proposed with their associated equivalent circuits (Yong-Nong and Chih-Ming, 2013).

Ozone concentration measurements have been evaluated to the ozone production, yield and production energy cost. The ozone production yield and cost vary in the range of 15-55 g/kWh and 35-110 eV/molecule (Simek and Clupek, 2002). The maximum ozone generation concentration and ozone generation efficiency are obtained with the meshed-plate type electrode (Park *et al.*, 2006) and the highest energy efficiency for ozone production was obtained using high voltage pulses of approximately 150 n sec duration in Ar/O₂ mixtures (Lukes *et al.*, 2005).

In other hand, the solar energy source potential is 4.8 kWh/m²/day in Indonesia (Anonymous, 2016). A prototype system of ozone generator using solar energy could generate ozone gas from air at approximately 20 mgO₃/h (Potivejkul *et al.*, 1998). Based on, the above literatures, it was necessary to make design, implementation and test a ozone generator based on photovoltaic source.

The objectives of research were to make design, implementation, measurements and tests the ozone generator based on a photovoltaic source with flyback converter. It was investigated the corona discharge current waveforms due to dc voltages. The relations among the oxygen flow time, 10-50 min in 10 min steps, voltage levels and oxygen debits to the product of ozone concentrations were also investigated. As a comparison, it was investigated the corona discharge current waveforms based on the back up battery source.

MATERIALS AND METHODS

Figure 1 shows the basic planning block diagram of photovoltaic based ozone generation. The photovoltaic

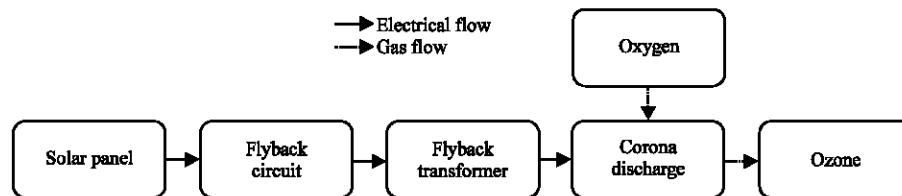

Fig. 1: Block diagram of photovoltaic based ozone generation

panel would produce the voltage of 12 V_{dc} nominally, it could reach 18 V_{dc}. Furthermore, this voltage would be raised to a high voltage which finally it was necessary to generate the ozone.

The specification of the used photovoltaic panel was 100 W_p of power. The open circuit voltage was 21.5 V, the short circuit current (I_{sc}) was 6.46 A, the Voltage at maximum power (V_{mp}) was 17.5 V_{dc} and the current at maximum power (I_{mp}) was 5.72 A. The flyback circuit, in Fig. 2, served to produce variable voltages (Nurendi *et al.*, 2015). Here was a chopper circuit used in the design of the ozone generator.

Figure 2, it was used RC oscillator circuit as the oscillator generation. The used transistors in the circuit were made up of transistors TIP32C and BU4522AF. The function TIP32C PNP transistor was for an amplifier to a digital circuit. While BU4522AF transistor was as a trigger in the circuit that served to supply current to the transformer. BU4522AF transistor also served as a safety in the event of over current. The following equations are used to calculate the above circuit:

$$f = \frac{1}{T} \tag{1}$$

$$f_0 = \frac{1}{2\pi RC} \tag{2}$$

$$C = \frac{C_1 \times C_2}{C_1 + C_2} \tag{3}$$

$$V_1 = \frac{R_3}{R_1 + R_2 + R_3} V_{in} \tag{4}$$

$$V_2 = \frac{R_8}{R_7 + R_8} V_1 \tag{5}$$

$$V_B = V_2 - V_{BE} \tag{6}$$

$$I_B = \frac{V_B}{R_9} \tag{7}$$

In this research, after obtaining the high voltage, it was necessary to produce ozone. The high voltage was connected to the plate conductor as generator of corona, taken place with 3 variables for each condition by adjusting the voltage to generate corona and two oxygen debits for ozone production. Figure 3 shows the planned electrodes that would generate ozone gas that insulated by Pyrex tube.

When the electric field at the surface of energized conductor exceeds 2-3 kV/mm, audible and sometimes visible corona discharges occurs (Jones, 1972). In this research, the Pyrex insulator tube was designed that had the following specification: 30 cm in length, 20 mm in diameter, 10 mm in radius and 0.5 mm in radius of inside copper conductor.

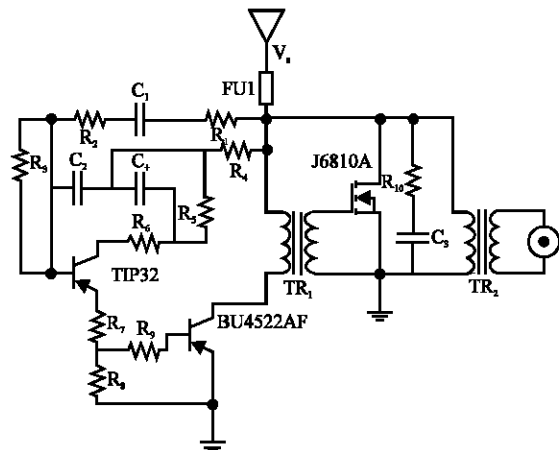

Fig. 2: Flyback circuit

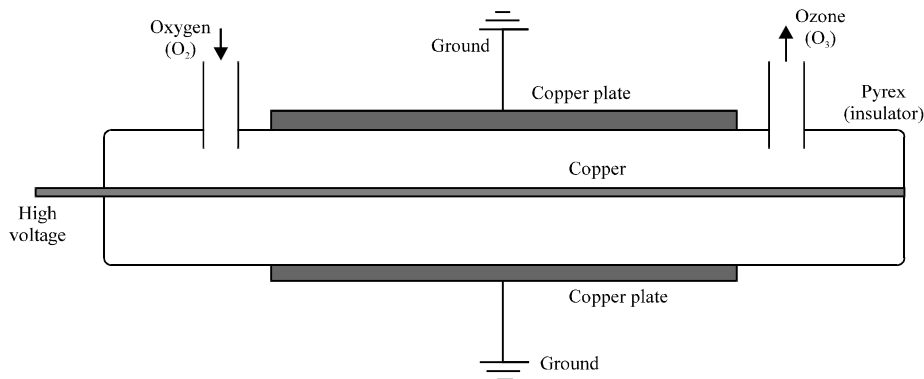

Fig. 3: Ozone generation electrodes

The used electrodes was installed in two different places, namely inside the tube and outside covering, circular, the Pyrex tube. Corona discharge begins when an electric field around the active electrode to form highly curved geometry has the ability to ionize the gas species (Moon and Jung, 2007). To determine the distance (x) that corona appeared, furthermore, the electric field in this experiment could be determined by the following Eq. 8:

$$E = \frac{V}{x \ln\left(\frac{R}{r}\right)} \quad (8)$$

Where, E, V, x, R and r were electric field, applied voltage, distance of the corona occurred, outside conductor radius on the cylinder and copper wire radius, respectively. The minimum voltage to be corona could be calculated using Eq. 8, namely for 2 kV/mm electric field. Thus, the necessary minimum voltage was 2.996 V or around 3 kV. Nevertheless, the generated voltage in the designed circuit was around 3-7 kV. Therefore, the maximum distance that corona discharge occurred was 1.3 mm radius.

In this testing, the voltage source from the photovoltaic source was raised by the flyback circuit, including the flyback transformer up to around 7 kV. Therefore, it would require a voltage divider circuit to facilitate the measurement up to around 7 kV. Thus, to get the original value of the measurement results, it should be carried out the following voltage divider circuit as Fig. 4 and the calculation method as Eq. 9:

$$V_i = \left[\frac{R_1 + R_2}{R_2} \right] V_o \quad (9)$$

Where V_i and V_o were the real voltage and the voltage measurement reading result. The resistors of

the voltage divider were $R_1 = 5.6, X 19 = 106.4$ and $R_2 = 3.3 M\Omega$. Besides that, the differential probe multiplier constant was 500 times and the attenuation factor of the oscilloscope was 10. Thus, the multiplier factor of the recorded values in the storage digital oscilloscope to the real values was 1.662. Figure 5 shows the diagram of photovoltaic source ozone generation including the measuring system.

Photovoltaic power panel generated 12 up to 18 V_{dc} source. This dc source was connected to the flyback circuit of supply voltage. Having obtained the desired voltage, the voltage was raised by using the flyback transformer to generate corona. The oxygen in the gas tube was flowed into the reactor through the pipes at a rate that was set by the flow meter. The result of the oxygen flowing in the corona reactor tube was ozone. The generated ozone existence amount could be measured by using a spectrophotometer as an ozone monitor.

The measurement of remaining ozone concentrations in this experiment were actually the concentration of residual ozone. This case was due to the nature of ozone gas which was reactive. The ozone reactivity complicated for measurement of ozone solubility in water directly. To perform the calculation of the concentration of residual

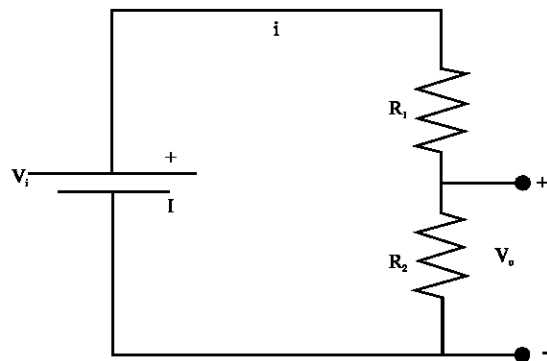

Fig. 4: Voltage divider circuit

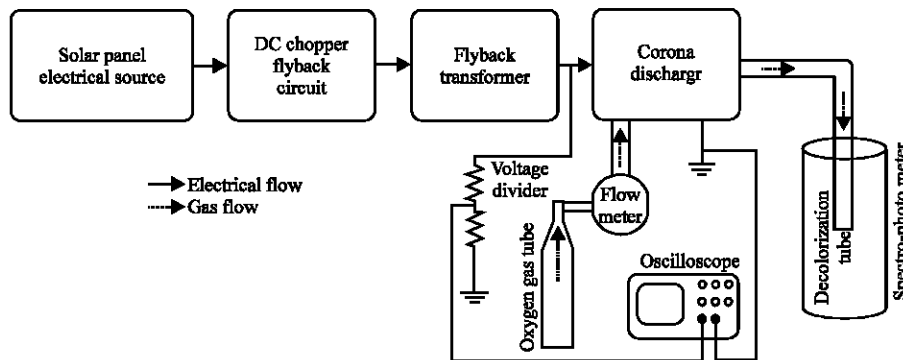

Fig. 5: Diagram of photovoltaic source ozone generation including the measuring system

ozone in the water, it was necessary to be done using the indigocalorimetry method and assisted by the spectrophotometer and by following Eq. 10:

$$C = \frac{50 \times \Delta A}{f \times b \times v} \left[\frac{\text{mgO}_3}{\text{L}} \right] \quad (10)$$

Where:

- ΔA = The difference of Absorbance between samples and blanks
- b = The length of the used cuvette (4.5 cm)
- v = The volume of sample water (9 mL)
- f = The 0.42 (based on the sensitivity factor of 20,000/cm for the change of absorbance 600 nm per mole of the addition of ozone per liter

RESULTS AND DISCUSSION

Figure 6 shows the main components of implemented photovoltaic source based ozone generation. Figure 6a is the panel that used as photovoltaic energy source. The used photovoltaic was 100 W_p as energy conversion from the sun light to the electric energy. Figure 6b shows the flyback dc chopper circuit and flyback transformer. The circuit generated high frequency as chopper of dc voltage. Furthermore, this dc voltage was multiplied to be high voltage by flyback transformer. The dc high voltage was entered to the electrode for producing corona discharge. Figure 6c shows the voltage divider for the measuring purpose of yielded high voltage to the storage digital oscilloscope. Finally, Figure 6d shows the ozone generator electrode where the device produced the ozone as consequence of corona discharge (Nurendi *et al.*, 2015).

The instruments for corona measurements were a differential probe, digital storage oscilloscope and laptop

or computer. The differential probe was for reducing the measured signals and safety purposes. The digital storage oscilloscope was as main instrument for applied high voltage and discharge current waveform measurements and the computer was for data savings after transferred from the digital storage oscilloscope. These data could be carried out for further analysis. Figure 7 shows the main instruments of oxygen and ozone measurements. Figure 7a shows oxygen tube which contained oxygen gas. The oxygen gas in this research was as raw material to produce ozone. Another one was a container tube to accommodate the generated ozone gas. Figure 7b shows a spectrophotometer to measure the concentration of generated ozone gas.

In this testing, the voltage source of the photovoltaic was raised by the flyback circuit and flyback transformer up to around 7,000 V. Therefore, it would required a voltage divider circuit to facilitate the measurements. Thus, to obtained the original value of the measurement results, it should be carried out to be multiplied certain factors. The calculation results based on Eq. 1 until Eq. 7 were 7,692.4; 7,525 Hz; 23.5 nF; 7.73 V; 5.26; 4.56 V and 9.7 mA, respectively. The electric field could be determined by using Eq. 8. It could be generated from every stage voltage, using 0.5 and 10 mm for inside and outside copper conductor radius, respectively. The calculation results of electric field are listed in Table 1.

Based on the calculations results of electric field, it was corona occurred in the design ozone reactor tube, both from the photovoltaic and battery sources as a comparison. In the maximum conditions, the output high voltages based on the photovoltaic were lower than those based on the battery, although, the photovoltaic voltage output was higher, 18 V_{dc}, than the battery voltage, 12 V_{dc}.

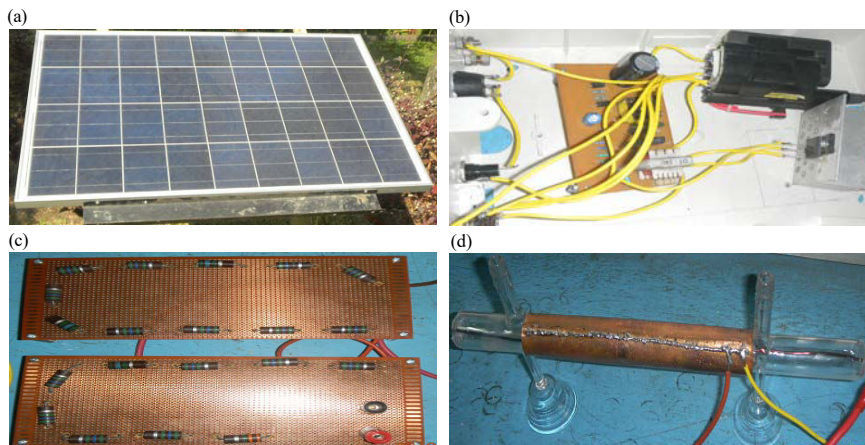

Fig. 6: The main components of photovoltaic based ozone generation: a) Solar panel; b) Flyback circuit and ignition coil; c) Voltage divider and d) Ozone generating electrode

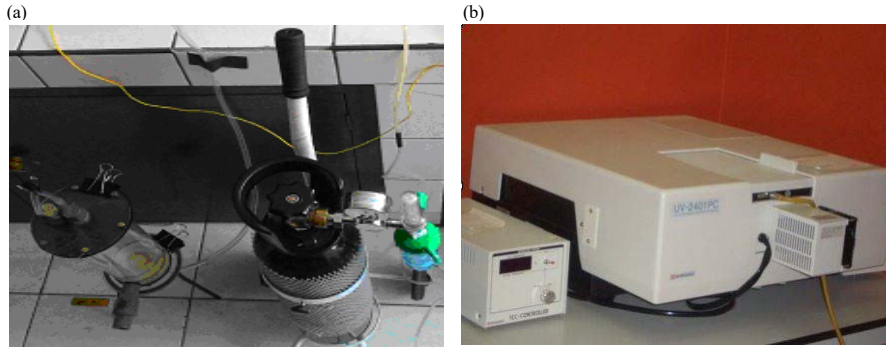

Fig. 7: The main instruments of oxygen and ozone measurements: a) Oxygen and ozone tubes and b) Spectrophotometer

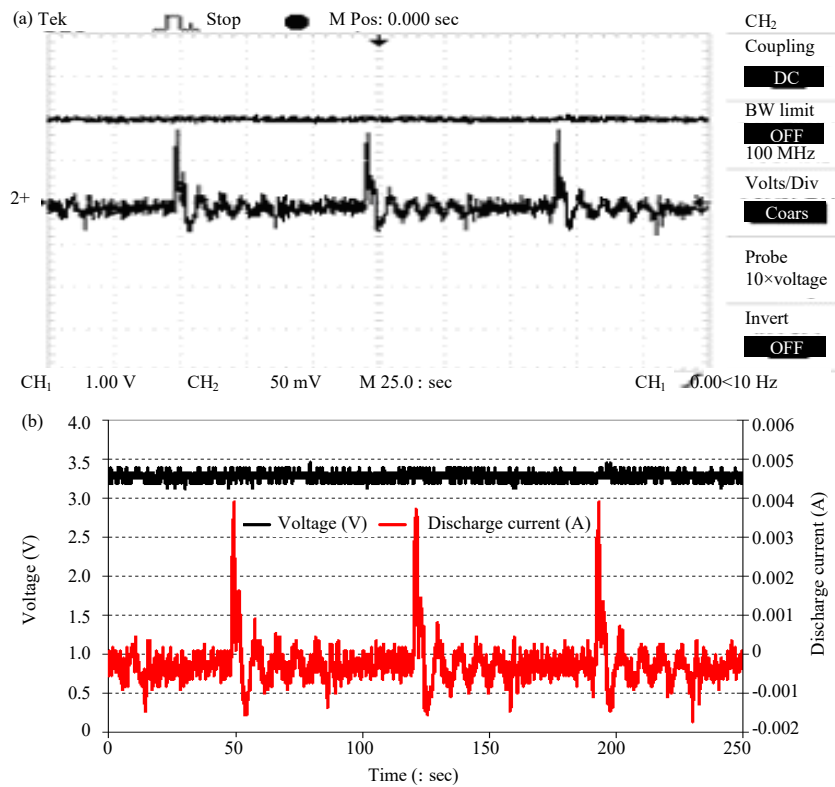

Fig. 8: The voltage and discharge current versus time on first stage: a) Original display and b) Converted display

Table 1: The calculations results of electric field

Stages of voltage	Photovoltaic output dc hv (V)	Photovoltaic output dc hv electric field (kV/cm)	12 V _{dc} battery output hv (V)	12 V _{dc} battery output dc hv electric field (kV/cm)
1	3.391	22.64	4.488	29.96
2	6.250	41.72	6.582	43.94
3	6.948	46.38	7.047	47.05

Thus, the electric field would be lower too. This case indicated that the battery was more stable due to corona discharge than the solar panel. Fig. 8 shows the voltage and discharge current versus time on first stage where

Fig. 8a is the original bitmap display and Fig. 8b is excel converted display. In this stage, the source voltage V_s from the photovoltaic was 18 V_{dc}, the voltmeter reading for the output voltage V_o was 75 V_{dc} and the converted calculation voltage for the output voltage V_o was 3391 V_{dc}. It was also indicated that based on this voltage, the peak discharge current was 3.9 mA in intermittent that signed corona appearing in the reactor tube.

Figure 9 shows that in the second stage with the source voltage of 18 V_{dc} from the solar panel where Fig. 9a is the original bitmap display and Fig. 9b is excel

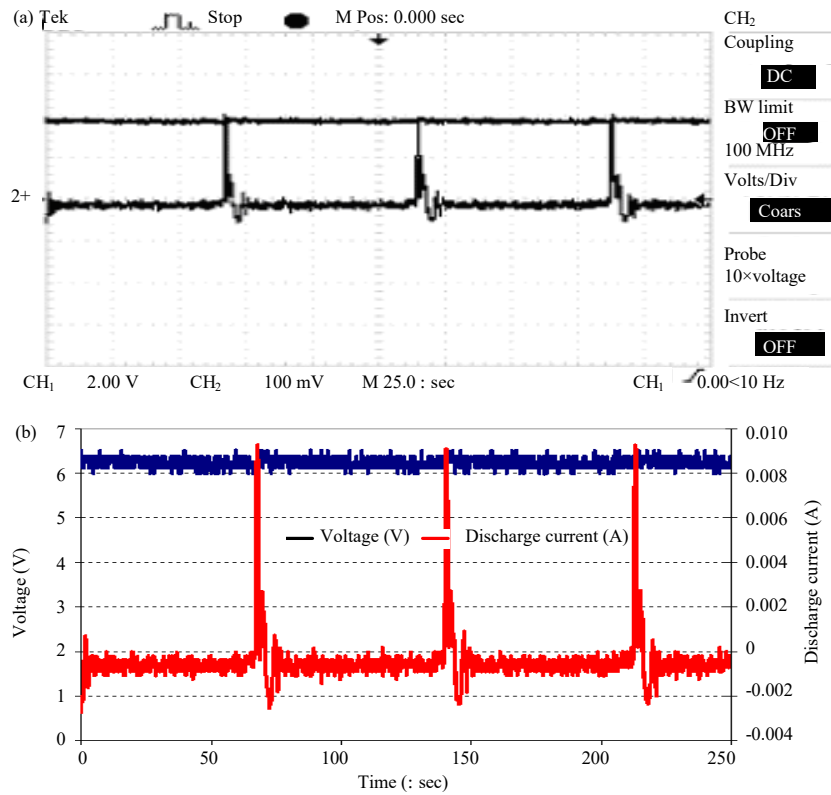

Fig. 9: The voltage and discharge current versus time on the second stage: a) Original display and b) Converted display

Table 2: The generated residual ozone concentration of the photovoltaic source first stage voltage

Time (min)	3 l/min oxygen debit (Q)		5 l/min oxygen debit (Q)	
	ΔA	mgO ₃ /L	ΔA	mgO ₃ /L
10	-0.005	-0.0147	-0.003	-0.0088
20	-0.003	-0.0088	-0.001	-0.0029
30	0.001	0.0029	0.001	0.0029
40	0.001	0.0029	0.003	0.0088
50	0.003	0.0088	0.004	0.0118

converted display. The voltmeter reading of output voltage was 180 V_{dc}. Thus, the output voltage became 6.250 V_{dc} that cause the peak discharge current of 9.2 mA in intermittent, indicating the appearance of the corona on the reactor tube.

Figure 10 shows that in the third stage with the source voltage of 18 V_{dc} from the solar panel where Fig. 10a is the original bitmap display and Fig. 10b is excel converted display. The voltmeter reading of output voltage was 200 V_{dc}. Thus, the output voltage became 6.948 V_{dc} that cause the peak discharge current of 11.2 mA in intermittent, indicating the appearance of the corona on the reactor tube.

Table 2 shows the number of absorbance measurement results using the spectrophotometer from the water sample that have undergone ozonation reaction with oxygen debit of 3 and 5L/min at the first

Table 3: Generated residual ozone concentration by the second stage voltage

Time (min)	3 l/min oxygen debit (Q)		5 l/min oxygen debit (Q)	
	ΔA	mgO ₃ /L	ΔA	mgO ₃ /L
10	-0.003	-0.0088	-0.001	-0.0029
20	-0.002	-0.0059	0.001	0.0029
30	0.001	0.0029	0.003	0.0088
40	0.003	0.0088	0.004	0.0118
50	0.005	0.0147	0.007	0.0206

voltage stage with 3.391 V_{dc} that has been raised by using the flyback circuit from the source of 18 V_{dc} output of solar panel. Table shows that each increment of interval time reveals the increase in the absorbance and the ozone concentration values of that have been produced.

Table 3 shows the number of absorbance measurement results using the spectrophotometer from the water sample that have undergone ozonation reaction with the oxygen debit of 3 and 5 L/min at the second stage from the photovoltaic source voltage of 18 V_{dc} where it was increased by using the flyback circuit upto 6.250 V_{dc}. Table shows that each increment of interval time reveals the increase in the absorbance and the ozone concentration values of that have been produced.

Table 4 shows the number of absorbance measurement results using the spectrophotometer from

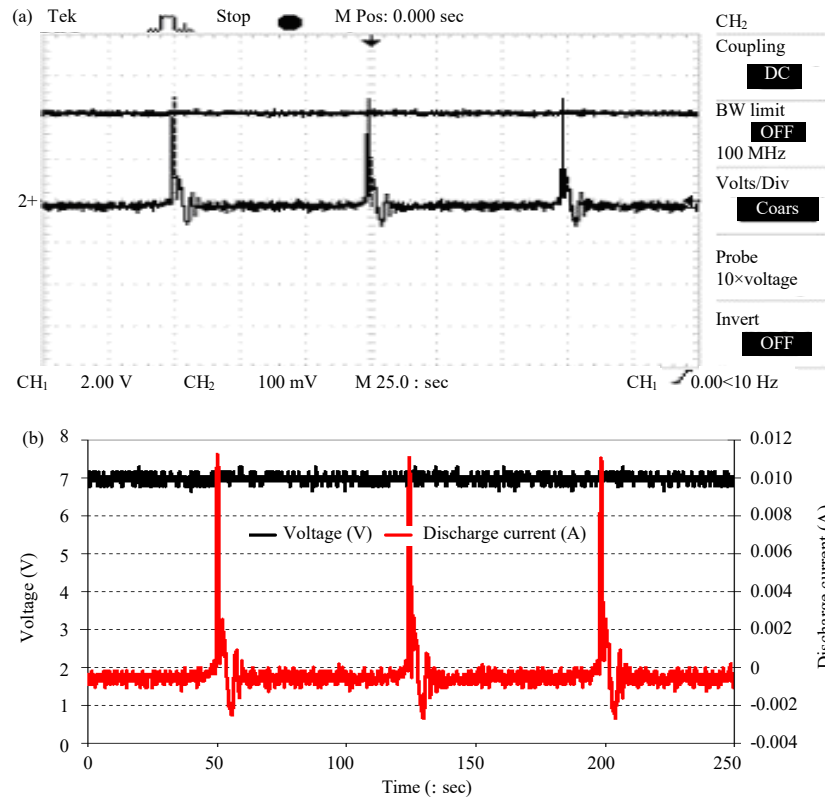

Fig. 10: The voltage and discharge current versus time on the third stage: a) Original display and b) Converted display

Table 4: Concentrations of residual ozone generated by the third stage voltage of photovoltaic source

Time (min)	3 l/min oxygen debit (Q)		5 l/min oxygen debit (Q)	
	ΔA	mgO ₃ /L	ΔA	mgO ₃ /L
10	-0.002	-0.0059	0.001	0.0029
20	0.002	0.0059	0.003	0.0088
30	0.003	0.0088	0.006	0.0176
40	0.005	0.0147	0.008	0.0235
50	0.008	0.0235	0.011	0.0323

water samples that have undergone ozonation reaction with the oxygen debit of 3 and 5 L/min at the third stage voltage of the photovoltaic source which has been raised using the flyback circuit from source 18 V_{dc} became 6.948 V_{dc}. Table 4 shows each increment of time reveals the increase in the absorbance and ozone concentration values that have been produced.

Figure 11 shows the relationship between the concentration of ozone and the ozonation time in the setting of oxygen flow rate of 3 and 5 L/min. These curves show the first, second and third stages of voltage. It reveals that the concentration of ozone product due to oxygen flow rate of 5 L/min would be higher than that 3 L/min. Besides that, the concentration of ozone product would rise as the voltage level increased and also the time increased too. The most substantial ozone formed

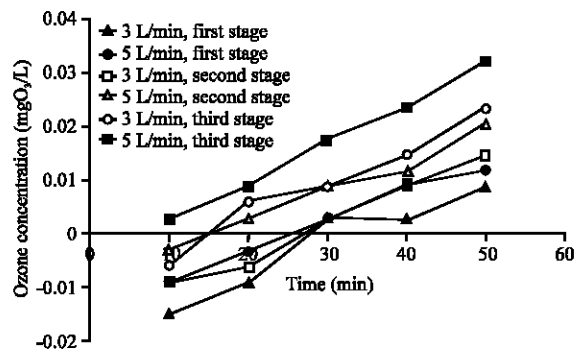

Fig. 11: Relationship between the ozonation time and the remaining ozone concentration in the oxygen debit of 3 and 5 L/min, for first, second and third stages of photovoltaic source

is shown in the stage 3 with the voltage of 6.948 V_{dc}, the oxygen flow rate of 5 L/min that produce ozone of 0.0323 mgO₃/L at 50 min.

Figure 12 shows a graph of the residual ozone concentration to voltage for 50 min. It can be seen that the formed ozone would increase as the voltage rise. It also reveals that the oxygen flow of 5 L/min would produced the ozone concentration greater than that the oxygen flow of 3 L/min.

As comparison, Fig. 13-15 show the voltage and discharge current versus time based on the 12 V_{dc} battery source (Nurendi *et al.*, 2015). Figure 14 shows the voltage and discharge current versus time for first stage. The voltmeter reading for V_o was 135 V_{dc} and the converted calculation voltage was 4.488 V_{dc}. It was also indicated that based on this voltage, the peak discharge current was 10.5 mA in intermittent that signed corona appearance in the reactor tube.

The data in Table 5 are the concentrations of residual ozone in water. The number of measurement results used the spectrophotometer absorbance of water sample had undergone the ozonation reaction with the oxygen debit of 3 and 5 L/min. Table also shows each increment of time that shows the increase of absorbing values.

Table 5: The generated residual ozone concentration of the battery source first stage voltage

Time (min)	3 l/min oxygen debit (Q)		5 l/min oxygen debit (Q)	
	ΔA	mgO ₃ /L	ΔA	mgO ₃ /L
10	-0.003	-0.0088	-0.004	-0.0118
20	0.002	-0.0059	0.002	-0.0059
30	0.003	0.0088	0.003	0.0088
40	0.004	0.0118	0.005	0.0147
50	0.006	0.0176	0.007	0.0206

Figure 14 shows that in the second stage, the output converted calculation voltage became 6,582 V_{dc} that cause the peak discharge current of 18.5 mA, indicating the appearance of the corona on the reactor tube. In this stage, the voltage meter reading V_o was 198 V_{dc}.

Table 6 shows the number of absorbance measurement results on the second stage voltage of 6582 V_{dc}. The table shows each increment of time reveals the increase in the absorbing values.

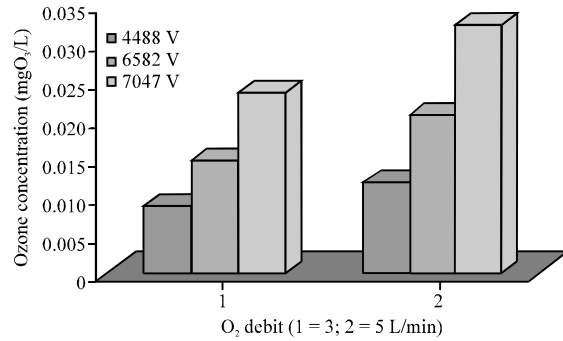

Fig. 12: The relationship between the remaining ozone concentration and voltage levels for both 3 and 5 L/min of oxygen debits in 50 min

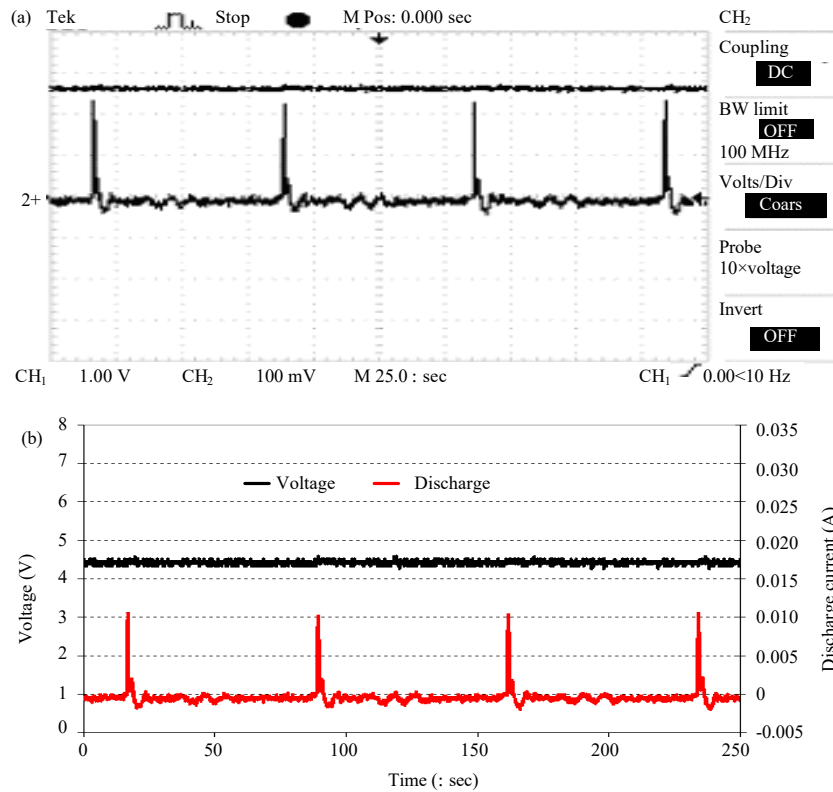

Fig. 13: The voltage and discharge current versus time on the first stage of battery source: a) Original display and b) Converted display

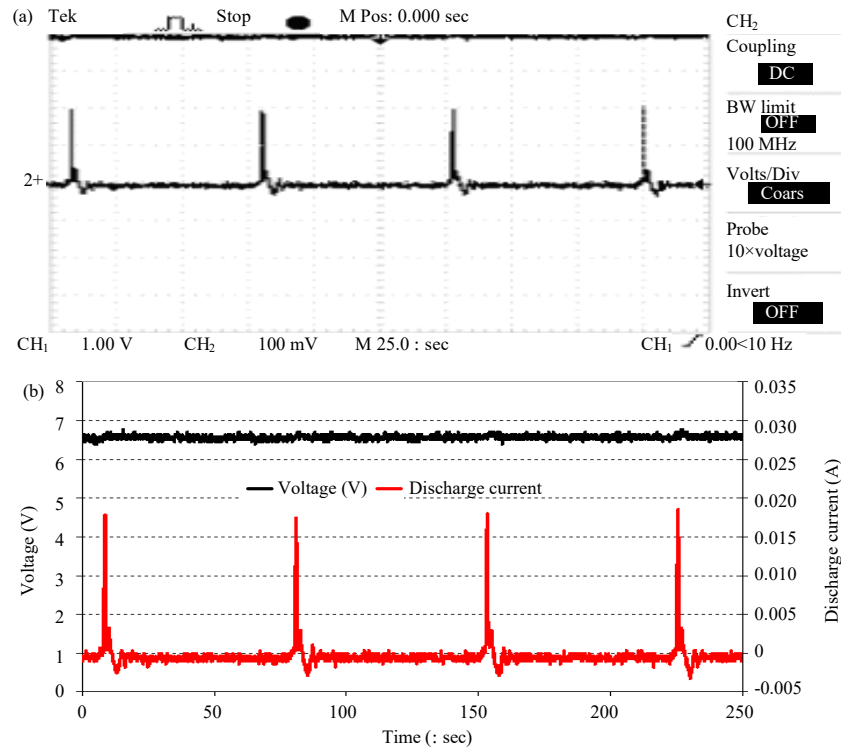

Fig. 14: The voltage and discharge current versus time on the second stage of battery source: a) Original display and b) Converted display

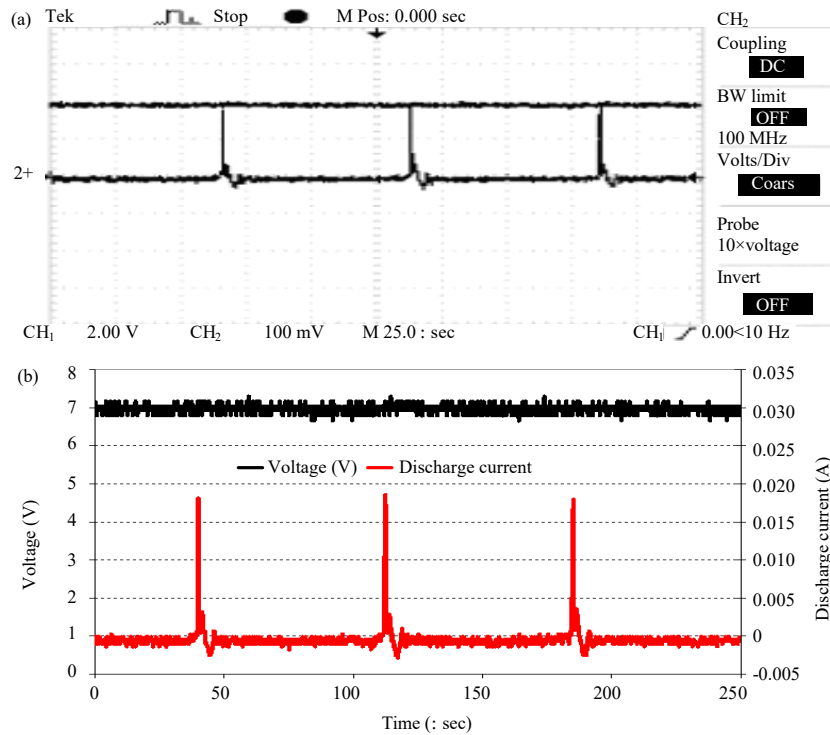

Fig. 15: The voltage and discharge current versus time on third stage of battery source: a) Original display and b) Converted display

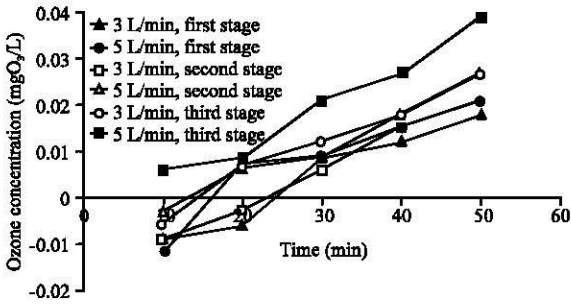

Fig. 16: Relationship between the ozonation time and the remaining ozone concentration in the oxygen debit of 3 and 5 L/min for first, second and third stages of battery source

Table 6: The generated residual ozone concentration of the battery source second stage voltage

Time (min)	3 l/min oxygen debit (Q)		5 l/min oxygen debit (Q)	
	ΔA	mgO ₃ /L	ΔA	mgO ₃ /L
10	-0.003	-0.0088	-0.001	-0.0029
20	-0.001	-0.0029	0.002	0.0059
30	0.002	0.0059	0.003	0.0088
40	0.005	0.0147	0.006	0.0176
50	0.007	0.0206	0.009	0.0265

Table 7: The generated residual ozone concentration of the battery source third stage voltage

Time (min)	3 l/min oxygen debit (Q)		5 l/min oxygen debit (Q)	
	ΔA	mgO ₃ /L	ΔA	mgO ₃ /L
10	-0.002	-0.0059	0.002	0.0059
20	0.002	0.0059	0.003	0.0088
30	0.004	0.0118	0.007	0.0206
40	0.006	0.0176	0.009	0.0265
50	0.009	0.0265	0.013	0.0382

Figure 15 shows that in the third stage, the output voltage was 7.047 V_{dc} which appearing the peak discharge current of 18.5 mA, indicating the appearance of corona on the reactor tube. The voltage reading was 212 V_{dc}.

Table 7 shows the number of absorbance measurement results using a spectrophotometer from water samples that have undergone ozonation reaction with the oxygen debit of 3 and 5 L/min at the third stage output voltage of 7.047 V_{dc} that could be calculated to determine the amount of residual ozone concentration has been produced. Table shows that each increment of time, it showed the increase in absorbing values.

Figure 16 shows the relationship between the concentration of ozone and the ozonation time in the setting of oxygen flow rate of 3 and 5 L/min from the battery source. These curves show the first, second and third stages of voltage. The concentration of ozone product due to the oxygen flow rate of 5 L/min would be higher than that 3 L/min. Besides that, the concentration of ozone product would rise as the voltage and the time

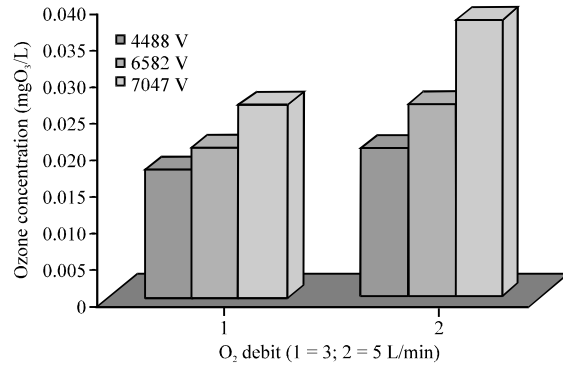

Fig. 17: The relationship between the remaining ozone concentration and and voltage levels for both 3 and 5 L/min of oxygen debits in the minute of 50 from the battery source

increased. The most substantial ozone formed was shown in the stage of 3 with the voltage of 7,047 V_{dc}, the oxygen flow rate of 5 L/min that produce ozone of 0.0382 mg O₃/L at 50 min.

Figure 17 shows the graph of residual ozone concentration to the voltage for 50 min. It can be seen that the formed ozone would increase as the voltage rise. It also reveals that the oxygen flow of 5 L/min would produced the ozone concentration greater than those the oxygen flow of 3 L/min from the battery source.

Based on the above figures and tables, it indicated that the most substantial ozone formed was shown in stage 3 with the voltage of 7.047 V_{dc} that produced ozone of 0.0382 mgO₃/L at 50 min. The corona could be seen without the use of visual aids by way of dimming the lights, so that the light emitted by the corona could be seen out through the tip end of the conductor. A corona was occurred if an electric field in the area around a conductor is higher than the field strength of air breakdown. The coronas due to electric field were occurred at both raised voltage of the battery and photovoltaic sources. The electric field magnitudes at the raised battery voltage source were greater than the photovoltaic source.

In the experiment using the direct source of solar panel, the ozone was produced by the three stages of generated voltage and by varying the flow rates of the oxygen debit of 3 and 5 L/min was with each experiment of 50 min and the recording data were in every 10 min. From the results of absorbing measurements to determine the concentration of residual generated ozone from each voltage using the calculation method of ozone concentration, it could be seen that the first stage of voltage produced 3.391 V_{dc} and the ozone product conducted by the rate of flow of oxygen debit of 5 L/min

was more than that debit of 3 L/min that was equal to 0.0118 mgO₃/L at minute of 50. In the second stage of voltage, it could be generated 6.250 V_{dc} and the ozone product conducted by varying the rate of flow of oxygen debit of 5 L/min was more than that debit of 3 L/min that was equal to 0.0206 mgO₃/L at 50 min. Finally, the third stage of generated voltage was 6.948 V_{dc} and the ozone product conducted by variation the flow rate of oxygen debit of 5 L/min was more than that the debit of 3 L/min that was as equal to 0.0323 mgO₃/L at 50 min.

In the experiments by using the source of battery, the generated ozone was produced by the 3 stages voltage levels, varying the flow rate of the oxygen debit of 3 and 5 L/min with each experiment 50 min and recording data per 10 min. The results of absorbing measurements to determine the concentration of generated residual ozone from each voltage level used the calculation method of ozone concentration, so that, it could be seen that the first stage was produced the voltage of 4.488 V_{dc} and the ozone results conducted by varying the rate of flow of oxygen to the debit of 5 L/min generated more ozone than the debit of 3 L/min was equal to 0.0206 mgO₃/L at 50 min. The second stage generated voltage of 6.582 V_{dc} and the ozone results conducted by varying the rate of oxygen flow to the debit of 5 L/min generated more ozone than the debit of 3 L/min that was equal to 0.0265 mgO₃/L at 50 min and the third stage voltage generated 7.047 V_{dc} and the ozone results were done with the flow rate variation oxygen debit of 5 L/min generated more ozone than the debit of 3 L/min that was equal to 0.0382 mgO₃/L at 50 min.

By doing two variations of the source of the above experiments, it could be seen that the source using the battery was better and produced more ozone due to the voltage on the battery was more stable. In contrast to the direct source of solar panel, although, the source voltage, 18 V_{dc}, greater than that the battery voltage, 12 V_{dc}, the output voltage after raising voltage using flyback circuit was smaller than the output voltage generated by the battery source. This case was predictly caused by the voltage on the photovoltaic was less stable, influenced by solar radiation and photovoltaic capacity. The discharge current generated by the solar panels was smaller than the current generated by the battery. The capacity of photovoltaic source was suspected as cause of smaller discharge current. Nevertheless, the voltage magnitude generated by the solar cell could be maintained in stable condition when using the battery and control charging with the constant voltage of 12 V_{dc}.

CONCLUSION

From the 18 V_{dc} source of the photovoltaic source at first stage, it was generated the high voltage of 3.391 V_{dc} and the ozone result conducted by the varying the flow rate of oxygen debit of 5 L/min generated more than that debit of 3 L/min that was equal to 0.0118 mgO₃/L at 50 min. From the 18 V_{dc} source of the photovoltaic panel at second stage, it was generated the high voltage of 6.250 V_{dc} and the ozone result conducted by the varying the flow rate of oxygen debit of 5L/min generated more than that debit of 3L/min that was equal to 0.0206 mgO₃/L at 50 min. From the 18 V_{dc} source of the photovoltaic at third stage, it was generated the high voltage of 6.948 V_{dc} and the ozone result conducted by the varying the flow rate of oxygen debit of 5 L/min generated more than that debit of 3 L/min that was equal to 0.0323 mgO₃/L at 50 min.

From the 12 V_{dc} source of the battery at first stage, it was generated the high voltage of 4.488 V_{dc} and the ozone result conducted by the varying the flow rate of oxygen debit of 5 L/min generated more than that debit of 3 L/min that was equal to 0.0206 mgO₃/L at 50 min. From the 12 V_{dc} source of the battery at second stage, it was generated the high voltage of 6.582 V_{dc} and the ozone result conducted by the varying the flow rate of oxygen debit of 5 L/min generated more than that debit of 3 L/min that was equal to 0.0265 mgO₃/L at 50 min. From the 12 V_{dc} source of the battery at third stage, it was generated the high voltage of 7.047 V_{dc} and the ozone result conducted by the varying the flow rate of oxygen debit of 5 L/min generated was more than that debit of 3 L/min that was equal to 0.0382 mgO₃/L at 50 min. The largest ozone result in oxygen debit of 3 L/min was produced by the third stage voltage at 0.0265 mgO₃/L whereas the largest ozone result of oxygen debit 5 L/min was generated by the third stage voltage of 0.0382 mgO₃/L.

The voltage source using battery was more stable and produced more ozone than that the photovoltaic panel. In contrast to the direct source of solar power, although, the source voltage was greater than the source voltage of the battery, however, after raising voltage using flyback circuit, it was smaller than the output voltage generated by the battery source. This case was predictly caused by the voltage on the photovoltaic energy source was not stable and influenced by solar radiation. The current generated by the photovoltaic panel was also smaller than that by the battery.

ACKNOWLEDGEMENT

This research was supported by the research institutions and community service (LP2M), Institut Teknologi Nasional Bandung (ITENAS).

REFERENCES

- Amjad, M., Z. Salam, M. Facta and K. Ishaque, 2012. Design and development of a high-voltage transformer-less power supply for ozone generators based on a voltage-fed full bridge resonant inverter. *J. Power Electron.*, 12: 387-398.
- Amjad, M., Z. Salam, M. Facta and S. Mekhilef, 2013. Analysis and implementation of transformerless LCL resonant power supply for ozone generation. *IEEE. Trans. Power Electron.*, 28: 650-660.
- Anonymous, 2016. International trade administration, renewable energy market assessment report. United States Department of Commerce, Washington, DC., USA.
- Boonseng, C., V. Kinnarees and P. Apriratikul, 2000. Harmonic analysis of corona discharge ozone generator using brush electrode configuration. *Proceedings of the IEEE International Conference on Power Engineering Society Winter Meeting Vol. 1, January 23-27, 2000, IEEE, Singapore*, pp: 403-408.
- Castle, G.P., I.I. Incullet and K.I. Burgess, 1969. Ozone generation in positive corona electrostatic precipitators. *IEEE. Trans. Ind. General Appl.*, 4: 489-496.
- Chalmers, I.D., L. Zanella and S.J. MacGregor, 1996. Ozone generation using pulsed corona in a wire/cylinder arrangement. *Proceedings of the IEEE International Conference on Colloquium on Pulsed Power, March 13, 1996, IEE, London, England, UK.*, pp: 1-7.
- Charlansut, A., M. Boonthienthong, S. Thongkeaw and P. Boonchiam, 2010. Study of ozone generator with electric fields distribution on water surfaces. *Proceedings of the 2nd RMUTP International Conference on Green Technology and Productivity, June 29-30, 2008, Pathumwan, Princess Hotel, Bangkok, Thailand*, pp: 1-4.
- Fukawa, F., N. Shimomura, T. Yano, S. Yamanaka and K. Teranishi *et al.*, 2008. Application of nanosecond pulsed power to ozone production by streamer corona. *IEEE. Trans. Plasma Sci.*, 36: 2592-2597.
- Goldman, M., A. Goldman and R.S. Sigmond, 1985. The corona discharge, its properties and specific uses. *Pure Appl. Chem.*, 57: 1353-1362.
- Hothongkham, P. and V. Kinnarees, 2009. Analysis and modelling of an ozone generator using a phase-shift PWM full bridge inverter. *Proceedings of the IEEE International Conference on Robotics and Biomimetics ROBIO, February 22-25, 2009, IEEE, Bangkok, Thailand, ISBN:978-1-4244-2678-2*, pp: 1619-1624.
- Izeki, N., 1983. Ozone generation mechanisms in ozonizer and future topics. *Proc. Inst. Electrostat. Japan*, 7: 142-149.
- Jones, B., 1972. *New Approaches to the Design and Economics of EHV Transmission Plant*. Pergamon Press, Oxford, England, UK., Pages: 248.
- Ketkaew, S., 2007. The case study of 5 kHz 25 kHz high frequency adjustment in converter circuit to generate ozone gas. *Au. J. Tech.*, 11: 42-47.
- LLC., 2015. *Installation and owner's manual, corona discharge CD10/AD ozone generator*. Limited Liability Company, Indian Harbour Beach, Florida.
- Loeb, L.B., 1965. *Electrical Coronas, their Basic Physical Mechanisms*. University of California Press, Berkeley, California, USA., Pages: 695.
- Lukes, P., M. Clupek, V. Babicky, V. Janda and P. Sunka, 2005. Generation of ozone by pulsed corona discharge over water surface in hybrid gas liquid electrical discharge reactor. *J. Phys. D. Appl. Phys.*, 38: 409-416.
- Ma, B., J. Andersson and S.M. Gubanski, 2010. Evaluating resistance of polymeric materials for outdoor applications to corona and ozone. *IEEE. Trans. Dielectr. Electr. Insul.*, 17: 555-565.
- Ma, B., S.M. Gubanski and H. Hillborg, 2011. AC and DC zone-induced ageing of HTV silicone rubber. *IEEE. Trans. Dielectr. Electr. Insul.*, 18: 1984-1994.
- Mattson, B., J. Michels, S. Gallegos, J. Ibanez and A. Alatorre-Ordaz, *et al.*, 2007. Microscale gas chemistry, Part 28. Mini-Ozone generator: 800 nanomole/minute. *Chem. News*, 344: 6-11.
- Mizuno, A., 2000. Electrostatic precipitation. *IEEE. Trans. Dielectr. Electr. Insul.*, 7: 615-624.
- Moon, J.D. and J.S. Jung, 2007. Effective corona discharge and ozone generation from a wire-plate discharge system with a slit dielectric barrier. *J. Electrostat.*, 65: 660-666.
- Moon, J.D., 1992. High efficiency ozone generation using a pyramidally embossed rod-to-cylinder electrode and a pulse corona discharge. *Proc. Inst. Electrostat. Japan*, 16: 224-229.
- Nurendi, D.M., W. Waluyo and S. Syahrial, 2015. [Design and realization of corona generator with DC source from 12 volt DC battery using flyback converter (In Indonesia)]. *Reka Elkomika*, 3: 87-96.

- Ohkubo, T., S. Hamasaki, Y. Nomoto, J.S. Chang and T. Adachi, 1990. The effect of corona wire heating on the downstream ozone concentration profiles in an air-cleaning wire-duct electrostatic precipitator. *IEEE. Trans. Ind. Appl.*, 26: 542-549.
- Panicker, P.K., F.K. Lu, G. Emanuel and B.T. Svihel, 2003. Ionization of air by corona discharge. Master Thesis, University of Texas at Arlington, Arlington, Texas.
- Park, S.L., J.D. Moon, S.H. Lee and S.Y. Shin, 2006. Effective ozone generation utilizing a meshed-plate electrode in a dielectric-barrier discharge type ozone generator. *J. Electrostat.*, 64: 275-282.
- Patil, J.G. and T. Vijayan, 2010. Characteristics of high-tension-induced corona-discharge plasma in ozone generator diode. *IEEE. Trans. Plasma Sci.*, 38: 2422-2427.
- Pontiga, F., C. Soria, A. Castellanos and J.D. Skalny, 2001. Physicochemical modeling of ozone generation in a negative corona discharge. *Proceedings of the International Conference on Electrical Insulation and Dielectric Phenomena*, October 14-17, 2001, IEEE, Kitchener, Ontario, Canada, pp: 412-415.
- Pontiga, F., H. Moreno and A. Castellanos, 2007. Ozone and Nitrogen oxides production by DC and pulsed corona discharge. *Proceedings of the 2007 International Conference on Annual Report Electrical Insulation and Dielectric Phenomena (CEIDP)*, October 14-17, 2007, IEEE, Vancouver, British Columbia, ISBN:978-1-4244-1481-9, pp: 671-674.
- Potivejkul, S., V. Kinnares and P. Rattanavichien, 1998. Design of ozone generator using solar energy. *Proceedings of the 1998 IEEE International Conference on Asia-Pacific Circuits and Systems*, November 24-27, 1998, IEEE, Chiangmai, Thailand, pp: 217-220.
- Pressman, S., 2001. The story of Ozone. *Plasmafire. Intl. Canada*, 1: 1-58.
- Samaranayake, W.J.M., E. Namihira, S. Katsuki, Y. Miyahara and T. Sakugawa *et al.*, 2001. Pulsed power production of ozone using nonthermal gas discharges. *IEEE. Electr. Insul. Mag.*, 17: 17-25.
- Sathalalai, S. and W. Khan-ngern, 2012. The study of temperature effect in electrode rods for ozone generation. *Eng. Appl. Sci. Res.*, 36: 323-331.
- Schiavon, G.J., C.M.G. Andrade, L.M.L. Jorge and P.R. Paraiso, 2012. Design and analysis of ozone generator operating at high frequency with digital signal controller. *Sci. Technol. Mag.*, 15: 23-35.
- Seinfeld, J.H. and S.N. Pandis, 1998. *Atmospheric Chemistry and Physics: From Air Pollution to Climate Change*. John & Sons, Hoboken, New Jersey, USA., ISBN:9780471178163, Pages: 1326.
- Simek, M. and M. Clupek, 2002. Efficiency of ozone production by pulsed positive corona discharge in synthetic air. *J. Phys. D. Appl. Phys.*, 35: 1171-1175.
- Smith, W., 2016. *Principles of ozone generation*. Watertec Engineering PTY Ltd., Beenleigh, Queensland.
- Szczepanski, M., D. Malec, P. Maussion, B. Petitgas and P. Manfe, 2017. Ozone concentration impact on the lifespan of enameled wires (conventional and corona-resistant) for low voltage rotating machines fed by inverters. *Proceedings of the 2017 IEEE International Conference on Electrical Insulation (EIC'17)*, June 11-14, 2017, IEEE, Baltimore, Maryland, ISBN:978-1-5090-3965-4, pp: 443-446.
- Tsai, M.T. and C.W. Ke, 2009. Design and implementation of a high-voltage high-frequency pulse power generation system for plasma applications. *Proceedings of the International Conference on Power Electronics and Drive Systems (PEDS'09)*, November 2-5, 2009, IEEE, Taipei, Taiwan, ISBN:978-1-4244-4166-2, pp: 1556-1560.
- Tudoran, C.D., 2011. High frequency portable plasma generator unit for surface treatment experiments. *Rom. J. Phys.*, 56: 103-108.
- Udhayakumar, G., M.R. Rashmi, K. Patel, G.P. Ramesh and A. Suresh, 2016. Implementation of high-frequency high-voltage power supply for ozone generator system using embedded controller. *Proceedings of the 2016 International Conference on Circuit, Power and Computing Technologies (ICCPCT'16)*, March 18-19, 2016, IEEE, Nagercoil, India, ISBN: 978-1-5090-1277-0, pp: 1-6.
- Vijayan, T. and J.G. Patil, 2011. Temporal development of ozone generation in electron-induced corona-discharge plasma. *IEEE. Trans. Plasma Sci.*, 39: 3168-3172.
- Wojtowicz, J.A., 2001. Use of ozone in the treatment of swimming pools and spas. *J. Swimming Pool Spa Ind.*, 4: 41-53.
- Yanallah, K., F. Pontiga, A. Fernandez-Rueda, A. Castellanos and A. Belasri, 2008. Ozone generation using negative wire-to-cylinder corona discharge: The influence of anode composition and radius. *Proceedings of the International Conference on Annual Report Electrical Insulation and Dielectric Phenomena (CEIDP)*, October 26-29, 2008, IEEE, Quebec, Canada, ISBN:978-1-4244-2548-8, pp: 607-610.
- Yong-Nong, C. and K. Chih-Ming, 2013. Design of plasma generator driven by high-frequency high-voltage power supply. *J. Appl. Res. Technol.*, 11: 225-234.

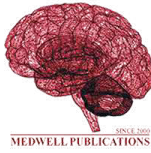

Related Links

[Abstract](#)

[Fulltext PDF](#)

[References](#)

Journals By Subject

[Agricultural Sciences](#)

[Animal Sciences](#)

[Applied Sciences](#)

[Business Sciences](#)

[Earth Sciences](#)

[Engineering](#)

[Information Technology](#)

[Medical Sciences](#)

[Molecular Sciences](#)

[Pharmacology](#)

[Social Sciences](#)

[Home](#) / [Journals](#) / [Journal of Engineering and Applied Sciences](#) / [Volume 13 Issue 1 ,Year 2018 Abstract](#) / [References](#)

Journal of Engineering and Applied Sciences

Year: 2018 | Volume: 13 | Issue: 1 | Page No. 105 - 118

DOI: [10.36478/jeasci.2018.105.118](https://doi.org/10.36478/jeasci.2018.105.118)

Ozone Production Based on Photovoltaic Source

Authors : [Waluyo](#) , [Deri Muhamad Nurendi](#), [Syahrial](#) and [Nasrun Hariyanto](#)

References

- Amjad, M., Z. Salam, M. Facta and K. Ishaque, 2012. Design and development of a high-voltage transformer-less power supply for ozone generators based on a voltage-fed full bridge resonant inverter. *J. Power Electron.*, 12: 387-398. [CrossRef](#) | [Direct Link](#) |
- Amjad, M., Z. Salam, M. Facta and S. Mekhilef, 2013. Analysis and implementation of transformerless LCL resonant power supply for ozone generation. *IEEE. Trans. Power Electron.*, 28: 650-660. [CrossRef](#) | [Direct Link](#) |
- Anonymous, 2016. International trade administration, renewable energy market assessment report. United States Department of Commerce, Washington, DC., USA.
- Boonseng, C., V. Kinnares and P. Apriratikul, 2000. Harmonic analysis of corona discharge ozone generator using brush electrode configuration. *Proceedings of the IEEE International Conference on Power Engineering Society Winter Meeting Vol. 1, January 23-27, 2000, IEEE, Singapore*, pp: 403-408.
- Castle, G.P., I.I. Inculet and K.I. Burgess, 1969. Ozone generation in positive corona electrostatic precipitators. *IEEE. Trans. Ind. General Appl.*, 4: 489-496. [CrossRef](#) | [Direct Link](#) |
- Chalmers, I.D., L. Zanella and S.J. MacGregor, 1996. Ozone generation using pulsed corona in a wire/cylinder arrangement. *Proceedings of the IEE International Conference on Colloquium on Pulsed Power, March 13, 1996, IEE, London, England, UK.*, pp: 1-7.
- Charlangsut, A., M. Boonthienthong, S. Thongkeaw and P. Boonchiam, 2010. Study of ozone generator with electric fields distribution on water surfaces. *Proceedings of the 2nd RMUTP International Conference on Green Technology and Productivity, June 29-30, 2008, Pathumwan, Princess Hotel, Bangkok, Thailand*, pp: 1-4.
- Fukawa, F., N. Shimomura, T. Yano, S. Yamanaka and K. Teranishi *et al.*, 2008. Application of nanosecond pulsed power to ozone production by streamer corona. *IEEE. Trans. Plasma Sci.*, 36: 2592-2597. [CrossRef](#) | [Direct Link](#) |
- Goldman, M., A. Goldman and R.S. Sigmond, 1985. The corona discharge, its properties and specific uses. *Pure Appl. Chem.*, 57: 1353-1362. [Direct Link](#) |
- Hothongkham, P. and V. Kinnares, 2009. Analysis and modelling of an ozone generator using a phase-shift PWM full bridge inverter. *Proceedings of the IEEE International Conference on Robotics and Biomimetics ROBIO, February 22-25, 2009, IEEE, Bangkok, Thailand, ISBN:978-1-4244-2678-2*, pp: 1619-1624.
- Izeki, N., 1983. Ozone generation mechanisms in ozonizer and future topics. *Proc. Inst.*

Jones, B., 1972. New Approaches to the Design and Economics of EHV Transmission Plant. Pergamon Press, Oxford, England, UK., Pages: 248.

Ketkaew, S., 2007. The case study of 5 kHz 25 kHz high frequency adjustment in converter circuit to generate ozone gas. Au. J. Tech., 11: 42-47.

[Direct Link](#) |

LLC., 2015. Installation and owner's manual, corona discharge CD10/AD ozone generator. Limited Liability Company, Indian Harbour Beach, Florida.

Loeb, L.B., 1965. Electrical Coronas, their Basic Physical Mechanisms. University of California Press, Berkeley, California, USA., Pages: 695.

Lukes, P., M. Clupek, V. Babicky, V. Janda and P. Sunka, 2005. Generation of ozone by pulsed corona discharge over water surface in hybrid gas liquid electrical discharge reactor. J. Phys. D. Appl. Phys., 38: 409-416.

[CrossRef](#) |

Ma, B., J. Andersson and S.M. Gubanski, 2010. Evaluating resistance of polymeric materials for outdoor applications to corona and ozone. IEEE. Trans. Dielectr. Electr. Insul., 17: 555-565.

[CrossRef](#) | [Direct Link](#) |

Ma, B., S.M. Gubanski and H. Hillborg, 2011. AC and DC zone-induced ageing of HTV silicone rubber. IEEE. Trans. Dielectr. Electr. Insul., 18: 1984-1994.

[CrossRef](#) | [Direct Link](#) |

Mattson, B., J. Michels, S. Gallegos, J. Ibanez and A. Alatorre-Ordaz, *et al.*, 2007. Microscale gas chemistry, Part 28. Mini-Ozone generator: 800 nanomole/minute. Chem. News, 344: 6-11.

[Direct Link](#) |

Mizuno, A., 2000. Electrostatic precipitation. IEEE. Trans. Dielectr. Electr. Insul., 7: 615-624.

[CrossRef](#) | [Direct Link](#) |

Moon, J.D. and J.S. Jung, 2007. Effective corona discharge and ozone generation from a wire-plate discharge system with a slit dielectric barrier. J. Electrostat., 65: 660-666.

[Direct Link](#) |

Moon, J.D., 1992. High efficiency ozone generation using a pyramidally embossed rod-to-cylinder electrode and a pulse corona discharge. Proc. Inst. Electrostat. Japan, 16: 224-229.

[Direct Link](#) |

Nurendi, D.M., W. Waluyo and S. Syahrial, 2015. [Design and realization of corona generator with DC source from 12 volt DC battery using flyback converter (In Indonesia)]. Reka Elkomika, 3: 87-96.

[Direct Link](#) |

Ohkubo, T., S. Hamasaki, Y. Nomoto, J.S. Chang and T. Adachi, 1990. The effect of corona wire heating on the downstream ozone concentration profiles in an air-cleaning wire-duct electrostatic precipitator. IEEE. Trans. Ind. Appl., 26: 542-549.

[CrossRef](#) | [Direct Link](#) |

Panicker, P.K., F.K. Lu, G. Emanuel and B.T. Svihel, 2003. Ionization of air by corona discharge. Master Thesis, University of Texas at Arlington, Arlington, Texas.

Park, S.L., J.D. Moon, S.H. Lee and S.Y. Shin, 2006. Effective ozone generation utilizing a meshed-plate electrode in a dielectric-barrier discharge type ozone generator. J. Electrostat., 64: 275-282.

[CrossRef](#) |

Patil, J.G. and T. Vijayan, 2010. Characteristics of high-tension-induced corona-discharge plasma in ozone generator diode. IEEE. Trans. Plasma Sci., 38: 2422-2427.

[CrossRef](#) | [Direct Link](#) |

Pontiga, F., C. Soria, A. Castellanos and J.D. Skalny, 2001. Physicochemical modeling of ozone generation in a negative corona discharge. Proceedings of the International Conference on Electrical Insulation and Dielectric Phenomena, October 14-17, 2001, IEEE, Kitchener, Ontario, Canada, pp: 412-415.

Pontiga, F., H. Moreno and A. Castellanos, 2007. Ozone and Nitrogen oxides production by DC and pulsed corona discharge. Proceedings of the 2007 International Conference on Annual Report Electrical Insulation and Dielectric Phenomena (CEIDP), October 14-17, 2007, IEEE, Vancouver, British Columbia, ISBN:978-1-4244-1481-9, pp: 671-674.

Potivejkul, S., V. Kinnares and P. Rattanavichien, 1998. Design of ozone generator using solar energy. Proceedings of the 1998 IEEE International Conference on Asia-Pacific Circuits and Systems, November 24-27, 1998, IEEE, Chiangmai, Thailand, pp: 217-220.

Pressman, S., 2001. The story of Ozone. *Plasmafire. Intl. Canada*, 1: 1-58.

[Direct Link |](#)

Samaranayake, W.J.M., E. Namihira, S. Katsuki, Y. Miyahara and T. Sakugawa *et al.*, 2001. Pulsed power production of ozone using nonthermal gas discharges. *IEEE. Electr. Insul. Mag.*, 17: 17-25.

[CrossRef | Direct Link |](#)

Sathalalai, S. and W. Khan-ngern, 2012. The study of temperature effect in electrode rods for ozone generation. *Eng. Appl. Sci. Res.*, 36: 323-331.

[Direct Link |](#)

Schiavon, G.J., C.M.G. Andrade, L.M.L. Jorge and P.R. Paraiso, 2012. Design and analysis of ozone generator operating at high frequency with digital signal controller. *Sci. Technol. Mag.*, 15: 23-35.

Seinfeld, J.H. and S.N. Pandis, 1998. *Atmospheric Chemistry and Physics: From Air Pollution to Climate Change*. John & Sons, Hoboken, New Jersey, USA., ISBN:9780471178163, Pages: 1326.

Simek, M. and M. Clupek, 2002. Efficiency of ozone production by pulsed positive corona discharge in synthetic air. *J. Phys. D. Appl. Phys.*, 35: 1171-1175.

[Direct Link |](#)

Smith, W., 2016. *Principles of ozone generation*. Watertec Engineering PTY Ltd., Beenleigh, Queensland.

Szczepanski, M., D. Malec, P. Maussion, B. Petitgas and P. Manfe, 2017. Ozone concentration impact on the lifespan of enameled wires (conventional and corona-resistant) for low voltage rotating machines fed by inverters. *Proceedings of the 2017 IEEE International Conference on Electrical Insulation (EIC'17)*, June 11-14, 2017, IEEE, Baltimore, Maryland, ISBN:978-1-5090-3965-4, pp: 443-446.

Tsai, M.T. and C.W. Ke, 2009. Design and implementation of a high-voltage high-frequency pulse power generation system for plasma applications. *Proceedings of the International Conference on Power Electronics and Drive Systems (PEDS'09)*, November 2-5, 2009, IEEE, Taipei, Taiwan, ISBN:978-1-4244-4166-2, pp: 1556-1560.

Tudoran, C.D., 2011. High frequency portable plasma generator unit for surface treatment experiments. *Rom. J. Phys.*, 56: 103-108.

[Direct Link |](#)

Udhayakumar, G., M.R. Rashmi, K. Patel, G.P. Ramesh and A. Suresh, 2016. Implementation of high-frequency high-voltage power supply for ozone generator system using embedded controller. *Proceedings of the 2016 International Conference on Circuit, Power and Computing Technologies (ICCPCT'16)*, March 18-19, 2016, IEEE, Nagercoil, India, ISBN:978-1-5090-1277-0, pp: 1-6.

Vijayan, T. and J.G. Patil, 2011. Temporal development of ozone generation in electron-induced corona-discharge plasma. *IEEE. Trans. Plasma Sci.*, 39: 3168-3172.

[CrossRef | Direct Link |](#)

Wojtowicz, J.A., 2001. Use of ozone in the treatment of swimming pools and spas. *J. Swimming Pool Spa Ind.*, 4: 41-53.

[Direct Link |](#)

Yanallah, K., F. Pontiga, A. Fernandez-Rueda, A. Castellanos and A. Belasri, 2008. Ozone generation using negative wire-to-cylinder corona discharge: The influence of anode composition and radius. *Proceedings of the International Conference on Annual Report Electrical Insulation and Dielectric Phenomena (CEIDP)*, October 26-29, 2008, IEEE, Quebec, Canada, ISBN:978-1-4244-2548-8, pp: 607-610.

Yong-Nong, C. and K. Chih-Ming, 2013. Design of plasma generator driven by high-frequency high-voltage power supply. *J. Appl. Res. Technol.*, 11: 225-234.

[Direct Link |](#)