



[Home](#) / [About the Journal](#)

About the Journal

Revue Roumaine des Sciences Techniques, Série Électrotechnique et Énergétique was founded in 1955, by the Section of Technical Sciences of the Romanian Academy. It is now published in one volume a year, consisting of 4 issues with a total average number of pages yearly of 480.

The review publishes original papers in English, French, German, and Russian, representing research on power economy, electrical power, electrical engineering, electronics, information transmission, computers, control systems in electrical power, thermopower, thermomechanics, bio-medical engineering, and connected problems. It reflects especially the fundamental and experimental research activity in power and communications of our country, papers presented at international conferences held in Romania, as well as the contributions of some specialists from abroad. A special part is assigned to reviewing the most relevant books, appearing in Romania and from abroad. The papers published are of the high level of the modern sciences and technique and represent original contributions to the development of contemporary power sciences. All manuscripts are strictly refereed and only papers of high quality, original, and with the application of the results, are accepted for publication. Through its topics, Revue is of concern to the specialists working in research and education, to the candidates for a doctoral degree, and to the students of the terminal years.

Revue has currently about 165 exchanges with representative journals of the domain from all over the world.

Revue Roumaine des Sciences Techniques, Série Électrotechnique et Énergétique is a journal of [the Romanian Academy](#), the [Engineering Section](#)

Language

[English](#)

[Français \(France\)](#)



Home / Archives / Vol. 66 No. 4 (2021): RRST-EE

Vol. 66 No. 4 (2021): RRST-EE



Published: 06.01.2022

Full Issue

[Contents 4/66/2021](#)

[Authors' Index](#)

[Reviewers](#)

[Scientific Support](#)

[Technical and Editorial Support](#)

Électrotechnique et électroénergétique / Electrical and Power Engineering

NEW SOLUTION OF ELECTROMAGNETIC LAUNCHER

DRAGOS NICOLESCU, ALEXANDRU RADULIAN, MIHAI MARICARU, SEBASTIAN PRICA, NICOLAE MOCIOI 213-217

[pdf file](#)

ARDUINO UNO-BASED AUTOMATIC TRANSFER SWITCH

WALUYO, KAMAL-SALAM SYAH, SITI SAODAH, DECY NATALIANA 219-224

[pdf file](#)

AN EFFICIENT HYBRID CONVERTER FOR DC-BASED RENEWABLE ENERGY NANOGRIID SYSTEMS

ANNAPOORANI SUBRAMANIAN, JAYAPARVATHY RAMAN, NAMMALVAR PACHAIVANNAN 225-230

[pdf file](#)

48 V NETWORK ADOPTION FOR AUTOMOTIVE LIGHTING SYSTEMS

COSTEL-CIPRIAN RAICU, GEORGE-CALIN SERITAN, BOGDAN_ADRIAN ENACHE 231-236

[pdf file](#)

REAL-TIME DISTRIBUTION SYSTEM ANALYSIS AND LOAD MANAGEMENT ALGORITHM FOR MINIMIZING HARMONICS

BASIT ALI, ABDUL ATTAYYAB KHAN 237-242

[pdf file](#)

IMPROVED HYBRID PUMPING SYSTEM WITH STOCKAGE BATTERY BASED ON PARTICLE SWARM ALGORITHM

FETHIA HAMIDIA, AMEL ABBADI 243-248

[pdf file](#)

ROBUST DESIGN OF POWER SYSTEM STABILIZER FOR A SINGLE GENERATOR-INFINITE BUS POWER SYSTEM

IMENE DEHIBA, MOHAMED ABID, ABDELGHANI AISSAOUI 249-253

[pdf file](#)

COMPARATIVE STUDY OF TWO CONTROL SCHEMES FOR MPPT STRATEGY OF A WIND SYSTEM

MOHAMED BOUTOUBAT, ABOUBAKEUR HADJAISSA, KHALED AMEUR 255-259

Language

English

Français (France)

 pdf file

Électronique et transmission de l'information / Electronics & IT

FREQUENCY LOCKED LOOPS OF THE THIRD AND HIGHER ORDER

DJURDJE PERIŠIĆ

261-266

 pdf file

Automatique et ordinateurs / Automation and Computer Sciences

PERFORMANCE ANALYSIS OF PROPORTIONAL INTEGRAL DERIVATIVE CONTROLLER WITH DELAYED EXTERNAL RESET AND PROPORTIONAL INTEGRAL DERIVATIVE CONTROLLER FOR TIME DELAY PROCESS

RAMAVEERAPATHIRAN ARUN, RATHINAM MUNIRAJ, MARIA SILUVAIRAJ WILLJUICE
IRUTHAYARAJAN

267-273

 pdf file

Thermotechnique et thermoénergétique / Thermotechnics and Thermal Energy

CALCULATION OF THE TEMPERATURES AND LIFETIMES FOR DISTRIBUTION TRANSFORMERS

PETRU V. NOTINGHER, CRISTINA STANCU, IONUT DRAGAN, MAAYA ISSEDOU BEY

275-284

 pdf file

ESTIMATION AND MAPPING OF LINKE TURBIDITY FACTOR FROM SOLAR RADIATION MEASUREMENT FOR INDIAN CLIMATIC CONDITIONS

NEELAM RATHORE, NARAYAN LAL PANWAR, FATIHA YETTOU, AMOR GAMA

285-294

 pdf file

Génie biomédical / Biomedical Engineering

SACRAL NEUROMODULATION - A NOVEL THERAPY FOR REFRACTORY OVERACTIVE BLADDER

CRISTIAN PERSU, STEFAN GUTUE, IRINA CIOFU, BOGDAN MIHAI, VICTOR CAUNI

295-299

 pdf file



[Home](#) / [Editorial Team](#)

Editorial Team

EDITORIAL COUNCIL

Prof. ALEXANDRU MIHAIL MOREGA, Member of the Romanian Academy
Acad. ION BOLDEA
Acad. IOAN DUMITRACHE
Acad. MIHAI-VIOREL BĂDESCU
Prof. VASILE MIHAI POPOV, Member of the Romanian Academy
Dr. ing. MIHAI N. MIHĂILĂ, Member of the Romanian Academy
Prof. ADRIAN BEJAN, Honorary Member of the Romanian Academy
Prof. VLADIMIR RĂSVAN
Prof. RADU MUNTEANU
Prof. dr. ing. AUREL CĂMPEANU
Prof. dr. ing. VICTOR CROITORU
Prof. dr. ing. ALEXANDRU ȘERBĂNESCU
Prof. dr. ing. THEODOR MICLESCU
Prof. dr. ing. GABRIEL BAZACLIU
Prof. dr. ing. FLOREA IOAN HĂNȚILĂ
Prof. dr. ing. CEZAR FLUERAȘU
Prof. dr. ing. FLORIN TUDOR TĂNĂSESCU
Prof. dr. ing. ION BĂNICĂ
Dr. ing. NICOLAE LEMNEAN
Dr. ing. MIHAI MARICARU
Dr. ing. IOSIF VASILE NEMOIANU
Prof. dr. ing. MIHAI OCTAVIAN POPESCU
Prof. dr. ing. VALENTIN NĂVRĂPESCU
Prof. dr. ing. LIVIU MARIO KREINDLER

EDITORIAL BOARD

Editor in Chief:

Prof. ALEXANDRU MIHAIL MOREGA, Member of the Romanian Academy

Deputy Editor-in-Chief:

Prof. FLOREA IOAN HĂNȚILĂ

Members:

Acad. ION BOLDEA
Dr. MIHAI N. MIHĂILĂ, Member of the Romanian Academy
Prof. VLADIMIR RĂSVAN
Prof. ION BĂNICĂ
Dr. MIHAI MARICARU
Dr. IOSIF VASILE NEMOIANU

Scientific Secretary:

†Eng. ANTOANETA SOCI

Language

[English](#)

[Français \(France\)](#)



[Home](#) / [Contact](#)

Contact

University Politehnica of Bucharest,
Faculty of Electrical Engineering,
Room EB228
Splaiul Independentei, no. 313, sector 6, PC 00642, Bucharest, Romania

Principal Contact

Editorial Team
revue@elth.pub.ro

Support Contact

Technical Support
revue@elth.pub.ro

Language

[English](#)

[Français \(France\)](#)

Rev Roumaine des Sciences Techniques-Series Electrotechnique et Energetique

COUNTRY

Romania



Universities and research institutions in Romania

SUBJECT AREA AND CATEGORY

Energy

└ Energy (miscellaneous)

Engineering

└ Electrical and Electronic Engineering

PUBLISHER

Editura Academiei Romane



Romanian Academy in Scimago Institutions Rankings

H-INDEX

16

PUBLICATION TYPE

Journals

ISSN

00354066

COVERAGE

1969-1970, 1972, 1974-1989, 2011-2021

INFORMATION

[Homepage](#)

[How to publish in this journal](#)

revue@elth.pub.ro

SCOPE

The journal Revue Roumaine des Sciences Techniques, Série Électrotechnique et Énergétique was founded in 1955, by the Section of Technical Sciences of the Romanian Academy. It is now published in one volume a year, consisting of 4 issues with a total average number of pages yearly of 480. The review publishes original papers in English, French, German and Russian, representing researches on power economy, electrical power, electrotechnics, electronics, information transmission, computers, control systems in electrical power, thermo power, thermotechnics, bio-medical engineering and connected problems interesting experts in power, electronics, control systems and communications. It reflects especially the fundamental and experimental research activity in power and communications of our country, papers presented at international conferences held in Romania, as well as the contributions of some specialists from abroad. A special part is assigned to reviewing the most relevant books, appearing in Romania and from abroad. The papers published are of high level of the modern sciences and technique and represent original contributions to the development of contemporary power sciences. All manuscripts are strictly referred and only papers of high quality, original and with application of the results, are accepted for publication. By its subjects, Revue is interesting the specialists working in research and education, as well as being candidates for a doctor's degree and the students of the terminal years.

Join the conversation about this journal

Quartiles



FIND SIMILAR JOURNALS ?

options ⋮

1

IEEE Transactions on Industry Applications

USA

22%

similarity

2

International Journal of Power and Energy Systems

CAN

22%

similarity

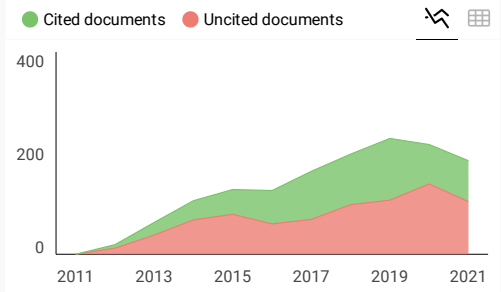
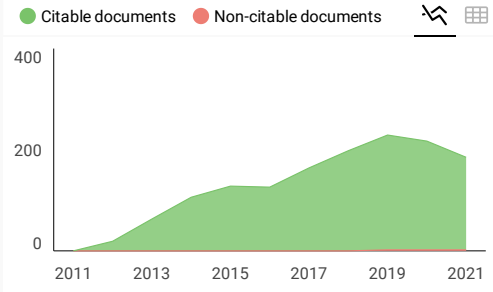
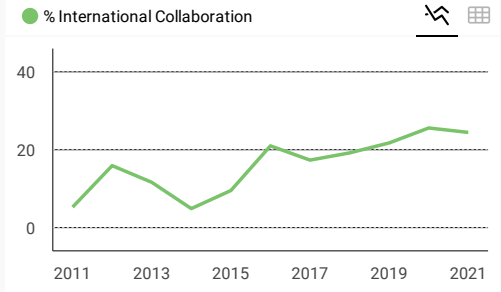
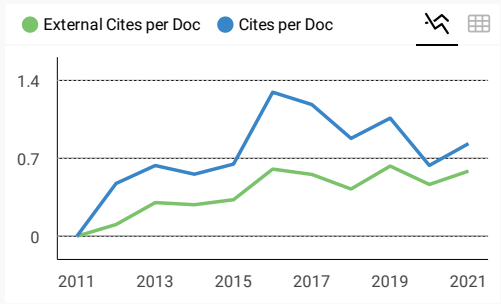
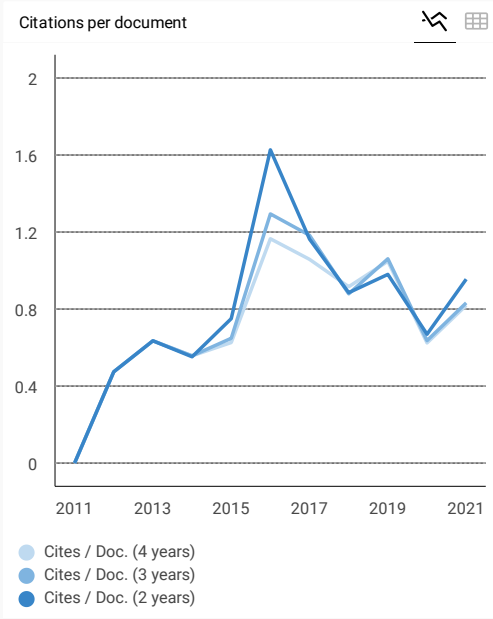
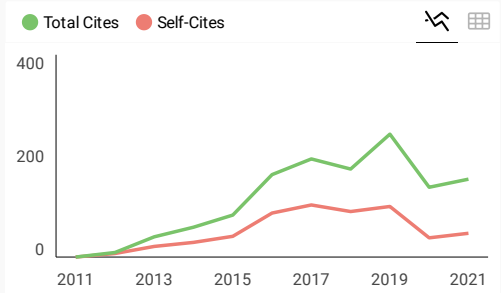
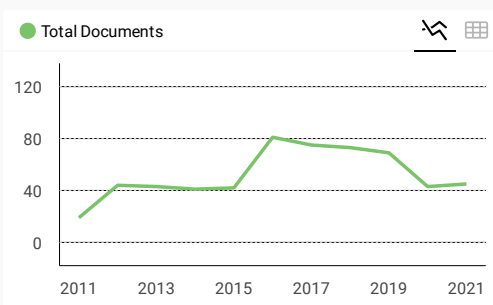
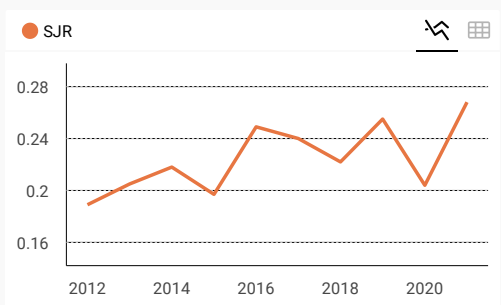

Rev Roumaine des Sciences Techniques-Series...

Q3

Electrical and Electronic Engineering

best quartile

SJR 2021

0.27

powered by scimagojr.com

← Show this widget in your own website

Just copy the code below and paste within your html code:

```
<a href="https://www.scimaç
```

Explore, visually communicate and make sense of data with our [new data visualization tool](#).

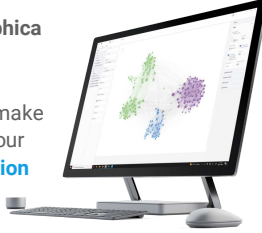

Metrics based on Scopus® data as of April 2022



MAHMOUD Imed 2 years ago

Dear Editor,

Please, how to publish in this journal(Rev Roumaine des Sciences Techniques-Series Electrotechnique et Energetique)?

Best regards
prof MAHMOUD Imed

 reply



Melanie Ortiz 2 years ago

SCImago Team

Dear Mahmoud, thank you very much for your comment, we suggest you look for the author's instructions/submission guidelines in the journal's website. Best Regards,
SCImago Team



husam 4 years ago

What is the published price in US dollars?

 reply



Elena Corera 4 years ago

SCImago Team

Dear Husam,

thank you very much for your comment, unfortunately we cannot help you with your request. We suggest you check author's instructions in journal website. You can find that information in SJR website <https://www.scimagojr.com>

Best Regards,
SCImago Team

Leave a comment

Name

Email

(will not be published)



I'm not a robot



reCAPTCHA
Privacy - Terms

Submit

The users of Scimago Journal & Country Rank have the possibility to dialogue through comments linked to a specific journal. The purpose is to have a forum in which general doubts about the processes of publication in the journal, experiences and other issues derived from the publication of papers are resolved. For topics on particular articles, maintain the dialogue through the usual channels with your editor.

Developed by:



Powered by:



Follow us on [@ScimagoJR](#)

Scimago Lab, Copyright 2007-2022. Data Source: Scopus®

EST MODUS IN REBUS

Horatio (Satire 1,1,106)

[Edit Cookie Consent](#)



Source details

Check whether you can access Scopus remotely through your institution

[Maybe later](#) [Check access](#)

Rev Roumaine des Sciences Techniques-Series Electrotechnique et Energeti

Scopus coverage years: from 1969 to 1970, 1972, from 1974 to 1989, from 2011 to 2022

Publisher: Editura Academiei Romane/Publishing House of the Romanian Academy

ISSN: 0035-4066

Subject area: [Energy: General Energy](#) [Engineering: Electrical and Electronic Engineering](#)

Source type: Journal

[View all documents >](#) [Set document alert](#) [Save to source list](#) [Source Homepage](#)

1.5

SJR 2021
0.268

SNIP 2021
0.520

[CiteScore](#) [CiteScore rank & trend](#) [Scopus content coverage](#)

i Improved CiteScore methodology

CiteScore 2021 counts the citations received in 2018-2021 to articles, reviews, conference papers, book chapters and data papers published in 2018-2021, and divides this by the number of publications published in 2018-2021. [Learn more >](#)

CiteScore **2021**

1.5 = $\frac{348 \text{ Citations 2018 - 2021}}{228 \text{ Documents 2018 - 2021}}$

Calculated on 05 May, 2022

CiteScoreTracker **2022**

1.4 = $\frac{331 \text{ Citations to date}}{235 \text{ Documents to date}}$

Last updated on 05 January, 2023 • Updated monthly

CiteScore rank 2021

Category	Rank	Percentile
Energy		
General Energy	#43/68	37th
Engineering		
Electrical and Electronic Engineering	#492/708	30th

[View CiteScore methodology >](#) [CiteScore FAQ >](#) [Add CiteScore to your site >](#)

About Scopus

- [What is Scopus](#)
- [Content coverage](#)
- [Scopus blog](#)
- [Scopus API](#)
- [Privacy matters](#)

Language

- [日本語版を表示する](#)
- [查看简体中文版本](#)
- [查看繁體中文版本](#)
- [Просмотр версии на русском языке](#)

Customer Service

- [Help](#)
- [Tutorials](#)
- [Contact us](#)



[Home](#) / [Archives](#) / [Vol. 66 No. 4 \(2021\): RRST-EE](#) /
Électrotechnique et électroénergétique / Electrical and Power Engineering

ARDUINO UNO-BASED AUTOMATIC TRANSFER SWITCH

Language

[English](#)

[Français \(France\)](#)

WALUYO

Department of Electrical Engineering, Institut Teknologi Nasional Bandung (Itenas), Bandung

KAMAL-SALAM SYAH

Department of Electrical Engineering, Institut Teknologi Nasional Bandung (Itenas), Bandung

SITI SAODAH

Department of Energy Conversion, Politeknik Negeri Bandung (Polban), Bandung

DECY NATALIANA

Department of Electrical Engineering, Institut Teknologi Nasional Bandung (Itenas), Bandung

Keywords: Arduino Uno, Automatic Transfer Switch, Backup source, Functional test, Voltage

Abstract

An automatic transfer switch (ATS) automatically transfers electrical power from a primary to a backup supply during power failure. However, there are some inconsistencies associated with this transfer method. Therefore, this research designed, constructed, and tested an Arduino Uno R3 board-based ATS prototype for the automatic transfer of electricity. This model generally consists of electrical equipment, electronic devices, and programming software. Furthermore, a ladder diagram in SoapBox Snap software, integrated with IDE software used to test the prototype. The ac relays were for the main and generator supply sensors, while the dc relays were for the generator switching, starting, and stopping processes. Basically, the capacities of the components for the main and backup generator supplies were based on 900 VA, 220 volts, 4.09 ampere, and 50 Hz for power, voltage, current, and frequency, respectively. Four functional tests were conducted on a normal, main supply outage, generator failure, and main supply conditions. The result showed that the main-to-backup supply switching time was 15.13 seconds, close to the standard time of 15 seconds. The average statistical error was 1.11% and was used as a third-class category of measuring instruments. Meanwhile, the operational voltage range was between 135 volts and 245 volts on loading conditions.

References

(1) E. Susanto, Automatic Transfer Switch (An Overview) (in Indonesian), Jurnal Teknik Elektro, 5, 1, pp.18-21 (2013).



[pdf file](#)

Published
06.01.2022

Issue
[Vol. 66 No. 4 \(2021\): RRST-EE](#)

Section
Électrotechnique et électroénergétique / Electrical and Power Engineering

(2) L. Olatomiwa, R. Olufadi, Design and development of a low-cost automatic transfer switch (ATS) with over-voltage protection, Journal of Multidisciplinary Engineering Science and Technology (JMEST), 1, 4, pp.190-196 (2014).

(3) P.H. Ginting, E.W. Sinuraya, Design of Automatic Transfer Switch (ATS) Transition Parameters in the form of Voltage and Frequency with Atmega 16 Microcontroller (in Indonesian), Transmisi, 16, 3, pp.128-134 (2014).

(4) P.H. Ginting, T. Sukmadi, E.W. Sinuraya, Design of Automatic Transfer Switch (ATS) Mode of Transition Open-Transition Re-Transfer with Transition Parameters in the Form of Voltage and Frequency (in Indonesian), Transient, 3, 1, pp.70-75 (2014).

(5) Ni Wayan Rasmini, Automatic Transfer Switch (ATS)-Automatic Main Failure (AMF) panel in BTDC Director Houses (in Indonesian), Jurnal Logic, 13, 1, pp.16-22 (2013).

(6) Suhanto, Design of Automatic Transfer Switch and Automatic System Mains Failure in Generator Set 80 kVA with Deep Sea Electronics 4420 (in Indonesian), Proceedings SENIATI, Malang, 3 Feb. 2018.

(7) E.T. Santosa, M. Sibarani, Suripto, Basic Design of Automatic Main Failure and Automatic Transfer Switch Systems for Building Meeting Room 71 (in Indonesian), Proceedings of Nuclear Device Engineering Scientific Meeting, PRPN-BATAN, Serpong, 30 Nov. 2011.

(8) F. Rahman, A. Natsir, G.W. Wahyu, Design of ATS/AMF as Automatic Power Supply Transfer Based Programmable Logic Control ((in Indonesian), Dielektrika, 2, 2, pp.164-172 (2015).

(9) A.B. Bimo, H. Santoso, Soemarwanto, Designing Automatic Transfer Switches on Motorbike Gasoline Generator-Set 1 Phase 2.8 kW 220 Volt 50 Hertz (in Indonesian), Jurnal EECCIS, 1, 1, pp.1-6 (2007).

(10) M.Q. Azeem, H.-ur Rehman, S. Ahmed, A. Khattak, Design and Analysis of Switching in Automatic Transfer Switch for Load Transfer, International Conference on Open Source Systems and Technologies (ICOSST), pp.129-134, Lahore, 15-17 Dec. 2016.

(11) C.K. Amuzuvi, E. Addo, A Microcontroller-Based Automatic Transfer Switching System for a Standby Electric Generator, Ghana Mining Journal, 15, 1, pp.85-92 (2015).

(12) A.F. Agbetuyi, A.A. Adewale, J.O. Ogunluyi, Design and Construction of An Automatic Transfer Switch for A Single Phase Power Generator, International Journal of Engineering Science, 3, 4, (2011).

(13) B. Anto, A Low Cost Microcontroller-Based Automatic Transfer Switch for Portable Generator, Proceedings SNPPTI, pp.239-245, Jakarta, 28 April 2012.

(14) C. Obasi, O.B. Odeyinde, J.J. Agidani, V.O. Ibiom, C.U., Osichinaka, Design and

Implementation of Microcontroller Based Programmable Power Changeover, Computer Engineering and Intelligent Systems, 6, 12, pp.51-56 (2015).

(15) A.P. Harahap, W. Dwiono, N. Harpawi, SMS Based Power Source Switching Hardware Series (in Indonesian), Jurnal Elektronika Industri, 5, pp.40-49 (2012).

(16) A.W. Indrawan, Hamdani, Nuraminah, Design of ATS/AMF Control and Monitoring Systems in the Transfer of Electric Energy Sources through the Internet Network (in Indonesian), Proceedings SNTEI, PNUP, 3 IT_020, pp. 262-271, Makassar, 3 Nov. 2016.

(17) R. Pakpahan, D.N. Ramadan, S. Hadiyoso, Design and Implementation Automatic Transfer Switch (ATS) Using Arduino Uno and Relay (in Indonesian), Jurnal Elektro Telekomunikasi Terapan, 3, 2, pp.332-341 (2016).

(18) E.C. John, E.V. Chioma, O.V. Onyeka, Single Phase Microcontroller-Based Automatic Change Over Switch, International Journal of Electronics, Communication & Instrumentation Engineering Research and Development (IJECIERD), 8, 1, pp.7-16 (2018).

(19) I.W. Suwardana, T.A. I Ketut, I.G.W.A. Kurniawan, Automatic Start Control Planning Hydrant Pump in Bali State Polytechnic (in Indonesian), Jurnal Logic, 13, 2, pp.106-114 (2013).

(20) Asriyadi, A.W. Indrawan, S. Pranoto, A.R. Sultan, R. Ramadhan, Design of Hybrid Automatic Transfer Switch (ATS) System (in Indonesian), Proceedings SNTEI, pp.408-414, Makassar, 3 Nov. 2016.

(21) V. Croitoru, I.A. Tihon, O. Leonte, V. Ciocoiu, T. Voica, M. Aranghel, I. Vonica, Data Acquisition System Based on Mobile Sensor Networks, Revue roumaine des sciences techniques Série Électrotechnique et Énergétique, 52, 1, p. 67-80 (2007).

(22) S.L. Stănescu, V. Sava, P.D. Cristea, M.V. Udrea, Firmware for Laser Surgical Ophthalmic Microscopes, Revue roumaine des sciences techniques Série Électrotechnique et Énergétique, 55, 4, p. 445-453 (2010).

(23) S. Das, P.K. Sadhu, S. Chakraborty, S. Banerjee, T. Saha, Design and Implementation of an Intelligent Dual Axis Automatic Solar Tracking System, Revue roumaine des sciences techniques Série Électrotechnique et Énergétique, Vol. 61, 4, pp. 383-387 (2016).

(24) B. Anton, A. Florescu, Ş.G. Roşu, Standalone Analog Active Cell-Balancing Circuit for Automotive Battery Management Systems, Revue roumaine des sciences techniques Série Électrotechnique et Énergétique, Vol. 63, 3, pp. 306-313 (2018).

(25) V.-M. Placinta, F. Babarada, C. Ravariu, L.G. Alecu, Digitally Controlled Electronic Load for Testing Power Supplies Reliability, Revue roumaine des sciences techniques Série Électrotechnique et Énergétique, Vol. 64, 2, pp. 131-136 (2019).

(26) L. Breniuc, C.G. Haba, V. David, Embedded Platform for Developing Medical Applications, Revue roumaine des sciences techniques Série Électrotechnique et Énergétique, Vol. 65, 1-2, pp. 123-129 (2020).

(27) National Standardization Body (BSN), SNI 0225, General Electrical Installation Requirements (PUIL) 2011, 8-21: Emergency (genset) generator installation, ICS90.140.50, Jakarta, 2011, p.573-580

(28) IEC, Electricity metering equipment (a.c.)-Particular requirements, IEC 62053-21, 1st Ed., Geneva, 2003, p.19-32.

(29) S.C. Chapra, Applied Numerical Methods with MATLAB® for Engineers and Scientists, 4th Ed., McGraw-Hill Education, New York, NY, USA, 2018, p. 100-103.

(30) P.T. PLN (Persero), Standard Voltages, SPLN 1, Jakarta, 1995, p.5.

ARDUINO UNO-BASED AUTOMATIC TRANSFER SWITCH

WALUYO¹, KAMAL SALAM SYAH¹, SITI SAODAH², DECY NATALIANA¹

Keywords: Arduino Uno, Automatic transfer switch, Backup source, Functional test, Voltage.

An automatic transfer switch (ATS) automatically transfers electrical power from a primary to a backup supply during power failure. However, there are some inconsistencies associated with this transfer method. Therefore, this research designed, constructed and tested an Arduino Uno R3 board based ATS prototype for the automatic transfer of electricity. This model generally consists of electrical equipment, electronic devices, and programming software. Furthermore, a ladder diagram in SoapBox Snap software, integrated with IDE software used to test the prototype. The ac relays were for the main and generator supply sensors, while the dc relays were for the generator switching, starting, and stopping processes. Basically, the capacities of the components for the main and backup generator supplies were based on 900 VA, 220 V, 4.09 A, and 50 Hz for power, voltage, current, and frequency, respectively. Four functional tests were conducted on a normal, main supply outage, generator failure, and main supply conditions. The result showed that the main-to-backup supply switching time was 15.13 s, closed to the standard time of 15 s. The average statistical error was 1.11 % and used as a third-class category of measuring instruments. Meanwhile, the operational voltage range was between 135 V and 245 V on loading conditions.

1. INTRODUCTION

The main electrical energy supply is not always continuous [1], therefore, it is necessary to use an ATS to transfer an alternative or backup power source to a load [2–4]. This tool controls backup generators and an automatic main failure (AMF) [5,6]. It reduces downtime and increases electrical power supply reliability [7]. Several ATSs have been designed using a programmable logic controller (PLC) [8], triode for alternating current (TRIAC) [9], PIC16F877 series [10–12], ATMEL ATtiny2313 [13], 8051 [14], ATmega 8535 [15], AVR ATmega16 [16], ATmega328 (on Arduino Uno board) [17], and 8052 [18] microcontrollers. Generally, these ATSs serve as a transfer-switch backup generator and are also used to turn on diesel pumps [19] and PV batteries [20].

Furthermore, microcontrollers are used to control various applications, such as data acquisition [21], microscope [22], solar tracking [23], battery management [24] systems, digital-controlled electronic load [25] and medical applications [26].

The statement above implies that microcontrollers have several benefits. However, the designed ATSs were not realized using SoapBox Snap software and tested not more than 15 times. In this research, the design, construction and testing of an ATS prototype control system were carried out using an Arduino Uno R3 board with ATmega328 microcontroller, SoapBox Snap for making ladder diagram, and carry out functional testing based on new ideas. This prototype was tested to show the time needed to transfer electrical energy from the primary to backup source, supposing the main power did not supply the load. Its

performance was also tested in case interference appeared between the primary and backup power sources with the standard transfer delay of 15 seconds [27]. Furthermore, the surge currents need to be overcome in the primary source and failure of the generator to start.

2. DESIGN AND IMPLEMENTATION METHODS

Figure 1 shows the block diagram of the ATS operational system consisting of input, process, and output. The first part is the main source and generator, while the second is the control system. The ac relay sensor was used to detect the main supply and backup generator, further processed by the Arduino Uno R3, which included ATmega 328 microcontroller as relay controller of on-off operations.

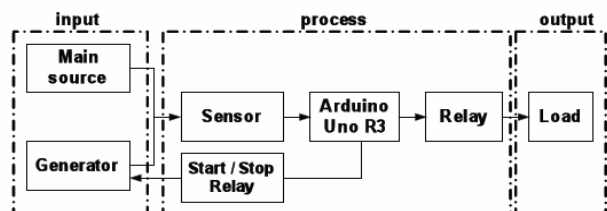

Fig. 1 – ATS system block diagram.

The maximum limit of the primary source and backup generator power requirement settings was necessary to avoid ATS component damages. Basically, the design was based on 900 VA, 220 V, 50 Hz, 0.8 lagging, for power, voltage, frequency, and power factor, respectively, both for the main and alternative sources. Therefore, the minimum current capacity was 4.09 A.

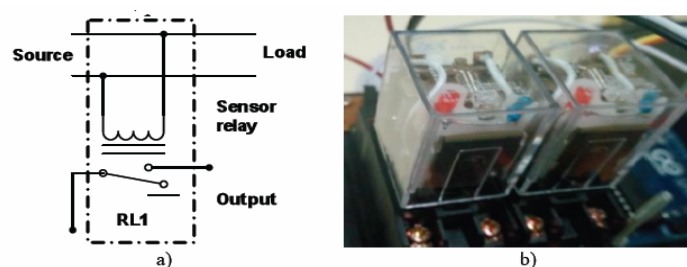

Fig. 2 – a) Voltage relay sensor circuit diagram; b) physical 250 V ac relay.

¹Department of Electrical Engineering, Institut Teknologi Nasional Bandung (Itenas), Bandung, Indonesia, email: waluyo@itenas.ac.id

²Department of Energy Conversion, Politeknik Negeri Bandung (Polban), Bandung, Indonesia.

The hardware subsystem consisted of a sensor, data processing, relay, and load. Figure 2a is a voltage sensor relay circuit diagram connecting the main supply and backup generator. Meanwhile, Fig. 2b shows the physical condition of the relay. In accordance with the energized coil, the relay is connected to the board.

The Arduino Uno R3 board serves as the data processing centre and controller. It required a 5 V dc operating voltage of power supply, connected to several hardware subsystem circuits, and located on a specified port according to the corresponding function. Figure 3 shows the Arduino Uno R3 pin locations.

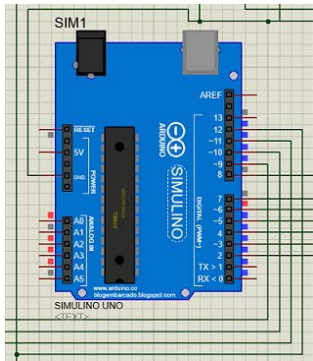

Fig. 3 – Arduino Uno R3 pin locations.

The Arduino Uno R3 board receives the input signals from the pushbuttons and sensing relays. Meanwhile, the output signals are from the indicator lamps and relays, such as starting, stopping, and loading. The dc modules are used for switches controlled by hardware. There are 2 subsystem relay types, which consist of the on and off starting and stopping backup generator and the on and off central source control relays.

Figure 4a shows the dc relay module circuit diagram. The input was connected to the Arduino Uno R3 board, while the output, which is in the form of a switch, moves the supplied energy from the main supply to the load in case the main source becomes extinct. Figure 4b indicates the physical 2-channel relay.

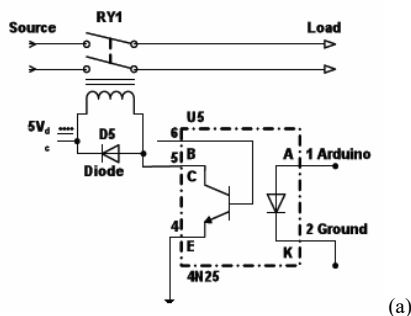

Fig. 4 – a) Circuit diagram and b) two-channel 5-volt dc relay.

The load subsystem was used to describe the ATS output. The lamps indicate the loading in the main supply or backup generator. The ATS used a 5 W LED, while the visual indications consisted of the load, backup generator stopping, and starting relay control indicator lamps.

The ATS programming was performed using a ladder diagram (LD) of SoapBox Snap software. It was also stimulated by LDmicro software without connecting to the hardware. The ladder design was based on 4 conditions, namely the normal, extinct, failed to start, and revived main supplies. However, the LD circuit was functional under normal conditions, while the main source was ready to supply the load. In accordance with this condition, the auto push button was on normally closed (NC). However, when the main supply goes extinct, the backup generator fails to operate. Figure 5 shows the corresponding flow chart.

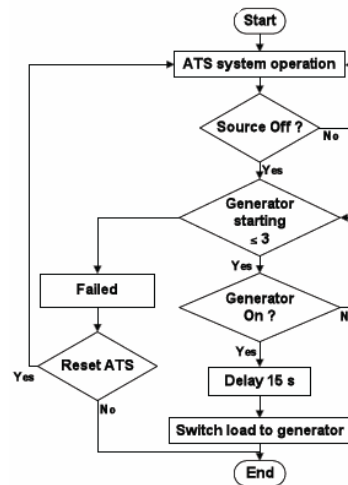

Fig. 5 – Failing and starting main supply flowchart.

In the case of a revived main supply, all relays are bound to start functioning. The flow chart describes this condition in Fig. 6.

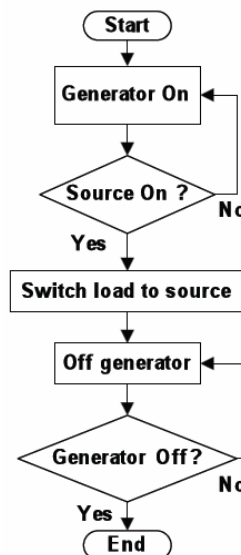

Fig. 6 – Revived primary source flowchart.

3. RESEARCH RESULTS AND DISCUSSION

Figure 7 shows the overall circuit diagram design, consisting of the main components, namely microcontroller and relays.

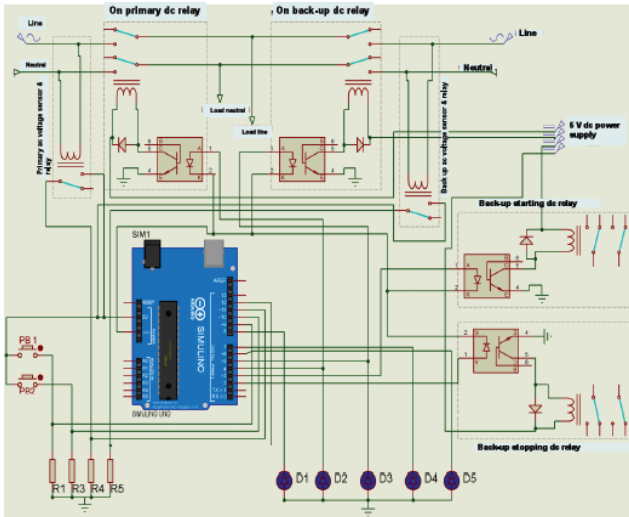

Fig. 7 – Overall ATS circuit diagram.

Figure 8 shows the ATS packaging, on the (a) outer and (b) inner parts, which consists of previously mentioned components.

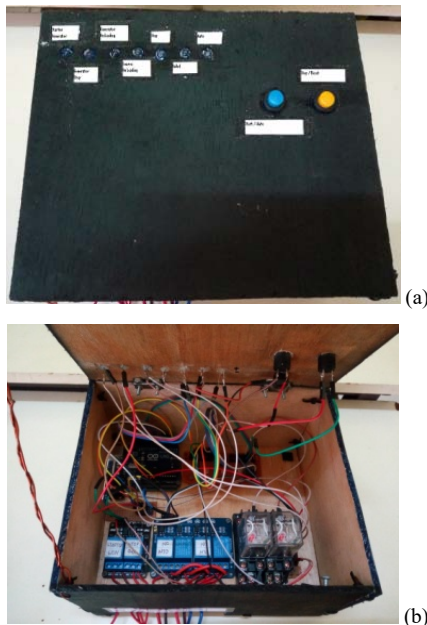

Fig. 8 – Yielded ATS: a) outside and b) inside.

In addition, testing of components was used to determine the ATS equipment’s feasibility, as shown in Fig. 9. analyzed, both operating voltage and statistical error.

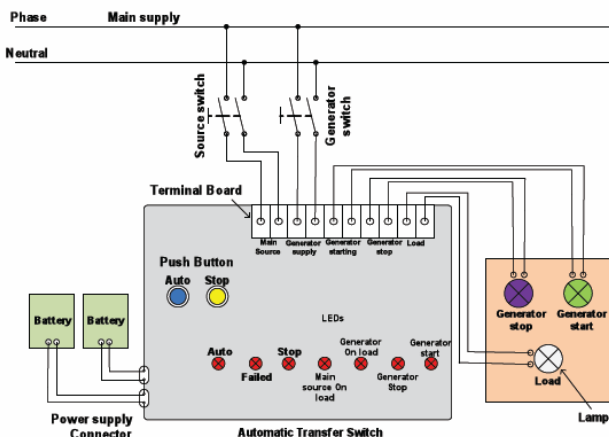

Fig. 9 – ATS testing circuit.

This process was carried out by connecting 2, 5 and 9 V, power supplies to the main supply of the Arduino Uno R3 board and dc relay circuits. The relay contacts were connected to a load of lamps through the terminal board. Conversely, the LEDs were connected in parallel to the main supply and the backup generator relay contacts. Furthermore, 2 incandescent lamps were connected to the ac source, starting from the relay contacts and the backup generator. To prevent the power source from extinction, some equipment was also tested and A power plant for emergency service needs to be able to reach full speed and carry load within 15 s after receiving the initial signal. The entire load also needs to be transferred within the next 30 seconds, or a total duration of 45 s [27]. In accordance with the standard basis, the ATS testing was carried out within 15 s. The main supply consists of 3 conditions, namely above, below and same as 15 s. It was further stimulated to determine the power outage of the main supply that lasted the duration. Based on the test data above 15 s, the ATS operated properly, by the switching from the main supply to the backup generator and vice versa. The test data below 15 s proved that the power outage of the main supply took place within a short time, under the ATS switching duration. The ATS below the 15 s operated adequately fulfilling the design. At the time of the main supply extinction, the backup generator started and functioned for 15 s, and the main supply came on before the time elapsed. The ATS ensured that the main supply was ready to transfer the load. After the 15 s waiting time, the relay turned off the backup generator.

The test data at the 15th second shows that the main supply was extinct, and at the same time, the backup generator was ready to start immediately, according to the standard, PUIL 2011 part 8 [27]. Based on the test data within the same duration, the ATS design was properly operated. It waited for the same duration to ascertain the availability of the voltage from the main supply. In the case of the extinct main supply voltage, the ATS initiated to start the backup generator for 15 s. In addition, the voltage supplied the load, which was also tested to certain occurrences. These include the inability of the generator to start and bringing the main supply back to life.

Figure 10 is a sample of a part ladder diagram under normal conditions using LDmicro software. The circuit and the main supply were ready to function and transfer the load. In this condition, the auto push button was on a normally close (NC).

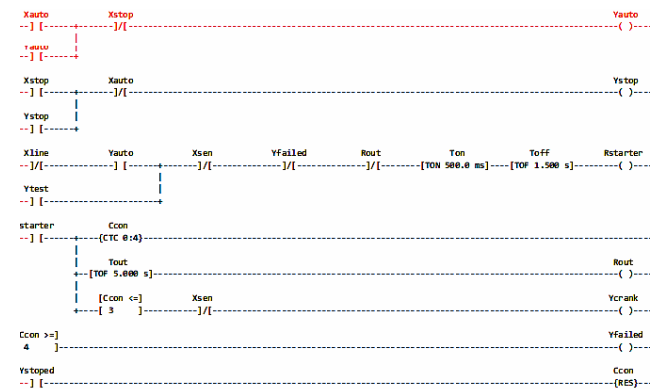

Fig. 10 – A sample of LDmicro ladder diagram.

Figure 11 shows the timing diagram for the healthy or normal condition. The result shows a turned on ATS and

load relay. It also illustrated the duration of the main active supply. Simultaneously, the backup generator was unable to handle the loss of power supply to the load. The experiment duration for the healthy condition was 120 s.

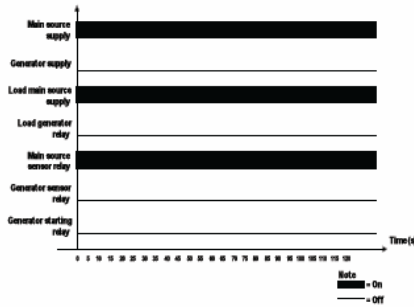

Fig. 11 – Healthy condition timing diagram.

Figure 12 shows the timing diagram of extinct main supply. The sensor becomes functional as the main supply is switched turned. Afterwards, the main supply was no longer available, and both load and supply sensor relays were turned off. The generator relay started for 15 s, after which it was ready to supply the load. The timing diagram describes the transfer time from the main supply to the generator, turned on for 15 s, and assuming the starting relay turned off, it was active for 2.5 s. The starting and warming of the generator lasted for the same duration. At 35th second, the supply turned on, followed by the load and sensor relays, for 87.5 s.

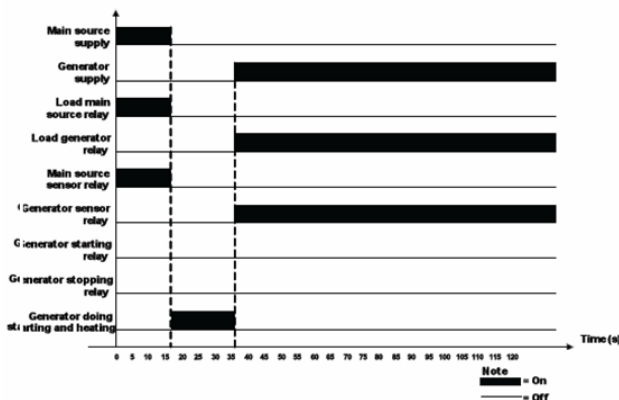

Fig. 12 – Extinct main supply timing diagram.

Figure 13 shows the timing diagram, which indicates the transfer duration from the generator to the main supply. This test was carried out for a returning state of the main supply to life. In this test, the main supply was extinct; the generator, load and sensor relays were turned on. Also, the main supply came back to life and was still turned on because it detected a voltage while the generator sensor relay was still active. It also failed to transfer the voltage until 15 s of set time to ensure that the main supply was fully ready to convey the load. After the stipulated time, the main supply relay was turned on, while the generator was turned off simultaneously. Furthermore, the generator started to cool for 15 s before getting turned off. The generator was turned on for 75 s, while the load and sensor relays were turned on for 45 s. At the 30th second, the main supply was turned on, and the timer waited for fifteen seconds to ascertain this fact. The generator was ready to supply power to the load. At the 45th second, the main supply conveyed electricity to the load, and the generator started cooling down and finally stopped at the 60th second.

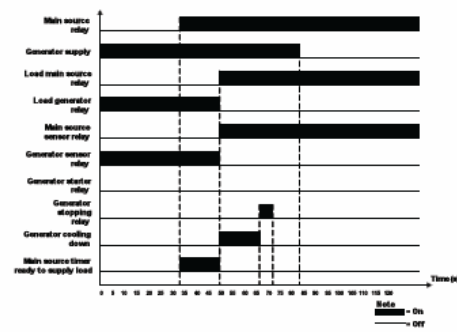

Fig. 13 – Return on a supply timing diagram.

Figure 14 shows the results of the test carried out when the generator failed to start. During this analysis, the main supply and sensor were turned on instead of the load relay. The generator relay, which was turned on, indicates that it tried to start. However, it failed, and the relay had to wait for 5 s, which depicts a first failed process. The relay was turned on to carry out other starting processes, and the generator failed to start again before being turned off for another 5 min. Moreover, the relay was turned on again to initiate a third starting process. It failed to start, and the relay waited for another 5 s. Therefore, both the buzzer and indicator lamp were turned on, indicating a problem with the backup generator.

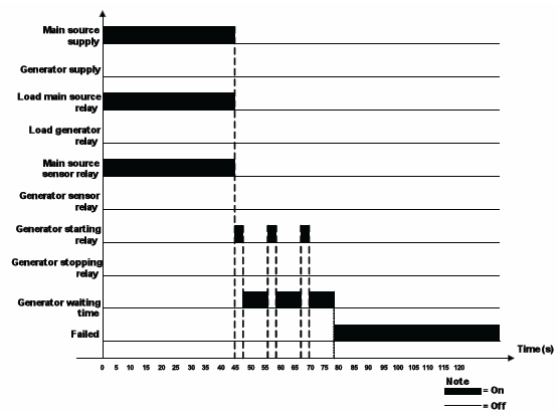

Fig. 14 – Failed generator to start timing diagram.

The main supply, relay, and sensor were set for 40 s. The generator relay turned on for 2.5 s, and the waiting time was 7.5 s to detect whether the generator failed. The starting of the generator was carried out 3 times to review whether or not it failed. After the 3rd time at the 70th second, it still failed to start, the buzzer and indicator lights were turned on, thereby depicting that the backup generator was the problem.

The main supply was above 15 s, while the starting signal duration was an average of 15.13 s. Conversely, when the main supply went out for less than 15 s, the ATS test data proved that the starting signal was an average of 15.20 s. It was further proven that the main source went off at 15 s, with a starting signal of 15.07 s. This case was in accordance with PUIL 2011, Section 8 [27], which stated that the power plant needs to be ready to supply load within 15 s of receiving signal.

The main supply needs to be revived, irrespective of the fact that the generator failed to start to avoid going extinct. Based on the healthy condition, the system was ready to respond to any interference. The extinct condition described the transfer time from the main supply to the backup

generator. Consequently, assuming the main supply was extinct, it conveyed the load to the backup generator within 15 s, according to the standard PUIL 2011 part 8 [27]. Although, when the main supply was revived, it was ready to supply the load. Finally, after 15 s, it moved from the backup generator to the main supply. Its inability to start led to a continuous trial of 3 more times before turning on the buzzer and indicator.

The ATS statistical and error tests are aimed to acquire the actual values. The error limit was listed on the measuring instruments with the electrical tools classified according to IEC 62053-21 standard [28]. The measuring instruments accuracy consists of 8 classes, namely 0.05, 0.1, 0.2, 0.5, 1.0, 1.5, 2.5 and 5. These describe the error magnitudes of the instruments on the measuring limits of $\pm 0.05\%$, $\pm 0.1\%$, $\pm 0.2\%$, $\pm 0.5\%$, $\pm 1.0\%$, $\pm 1.5\%$, $\pm 2.5\%$, $\pm 5\%$, to the maximum values. Based on these classes, the measuring instruments were classified into 4 groups according to the user criteria.

1. Groups of 0.05, 0.1, and 0.2 classes include the highest precision measuring instrument. They are used as laboratory standards.
2. The 0.5 measuring instrument class has the next lower level of precision after the 0.2 class. This measuring instrument is portable and commonly used for precision measurements.
3. The 1.0 class has a lower level of precision than that of the 0.5. This is commonly used on small portable or panel measuring instruments.
4. The 1.5, 2.5, and 5 classes are used on panels that do not pay much attention to precision and accuracy.

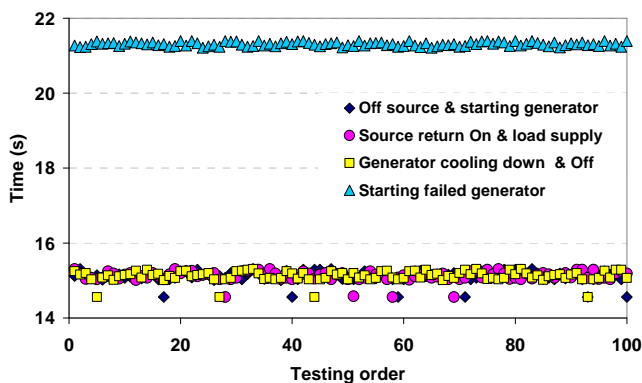

Fig. 15 – ATS testing results.

The testing process was carried out by measuring the response time of each part, which was carried out 100 times. The parts include the extinguished main source and starting generator, revived main supply and load. On the contrary, the starting generator handled the cooling down and turning off, while the backup failed to start. Figure 15 shows the ATS testing results.

Equation (1) is used to calculate the percentage of errors from the ATS system [29].

$$\text{error} = \frac{|X_n - X_o|}{X_o} 100 \text{ [\%]}, \quad (1)$$

where X_n and X_o are the n^{th} and initial data, respectively. The results of the error percentages are shown in Fig. 16. The mean value of the ATS error was 1.11 %, and it has a reasonably small percentage error because it has a systematized approach to the third class. The mistakes found in the generator's inability to start were at an average

of 1.47 % and close to the fourth category. This was caused by failures of the starting conditions, despite starting the generator 3 times in a reasonably long time.

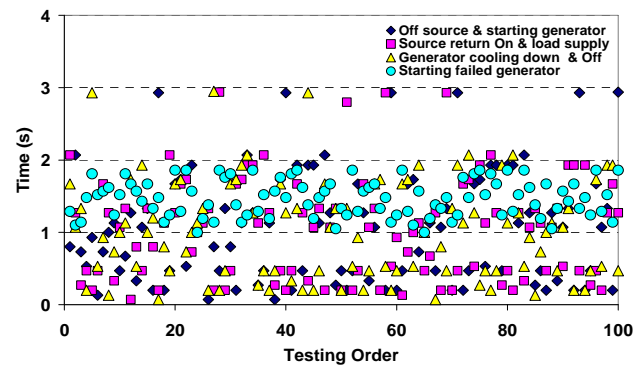

Fig. 16 – ATS error percentages.

The ATS service working voltage variation was set to $+5\%$ and -10% maximum and minimum nominal voltage [30]. Based on the quotation of SPLN 1995, Article 4, the test was carried out by adjusting the working voltage of 50 to 250 V on the ATS. It showed that the load supplied 50 to 134 V, while turning off their load condition. Meanwhile, the voltage range of 135 to 245 was also turned on.

4. CONCLUSION

In conclusion, an Arduino Uno-based automatic transfer switch prototype was successfully designed in this research. This prototype included SoapBox Snap software in the design, implementation and functional testing stages.

The yielded data for the main supply and generator were acquired 100 times. The main supply produced power, and the backup generator was cooled down and turned off. Meanwhile, the failure rate of the backup generator was 1.11 %. This case followed the standard [28] the yielded ATS was classified in the third class and closed to 1.0 %. This precision was commonly used on portable or panel measuring instruments.

The operating voltage data range from 50 to 134 led to the turned-off load condition. However, within the range of 135 to 245 V, it was turned on. This was proven to be greater than the standard [30], whereas the variation of the service voltage was set at $+5\%$ and -10% for the maximum and minimum of the nominal voltages, respectively. For future occurrences, it is better to design a prototype that reduces the starting time.

Received on February 9, 2021

REFERENCES

1. E. Susanto, *Automatic Transfer Switch (An Overview)* (in Indonesian), *Jurnal Teknik Elektro*, **5**, 1, pp.18-21, 2013.
2. L. Olatomiwa, R. Olufadi, *Design and development of a low-cost automatic transfer switch (ATS) with over-voltage protection*, *Journal of Multidisciplinary Engineering Science and Technology (JMEST)*, **1**, 4, pp. 190-196, 2014.
3. P.H. Ginting, E.W. Sinuraya, *Design of automatic transfer switch (ATS) transition parameters in the form of voltage and frequency with Atmega 16 microcontroller* (in Indonesian), *Transmisi*, **16**, 3, pp. 128-134, 2014.
4. P.H. Ginting, T. Sukmadi, E.W. Sinuraya, *Design of automatic transfer switch (ATS) mode of transition open-transition re-transfer with transition parameters in the form of voltage and frequency* (in Indonesian), *Transient*, **3**, 1, pp. 70-75, 2014.
5. N.W. Rasmini, *Automatic Transfer Switch (ATS)-automatic main failure (AMF) panel in BTDC director houses* (in Indonesian), *Jurnal Logic*, **13**, 1, pp. 16-22, 2013.

6. S. Suhanto, *Design of automatic transfer switch and automatic system mains failure in generator set 80 kVA with deep sea electronics 4420* (in Indonesian), Proc. SENIATI, Malang, 3 Feb., 2018.
7. E.T. Santosa, M. Sibarani, Satripto, *Basic design of automatic main failure and automatic transfer switch systems for building meeting room 71* (in Indonesian), Proc. of Nuclear Device Engineering Scientific Meeting, PRPN-BATAN, Serpong, 30 Nov., 2011.
8. F. Rahman, A. Natsir, G.W. Wahyu, *Design of ATS/AMF as automatic power supply transfer based programmable logic control* (in Indonesian), Dielektrika, **2**, 2, pp. 164-172, 2015.
9. A.B. Bimo, H. Santoso, Soemarwanto, *Designing automatic transfer switches on motorbike gasoline generator-set 1 phase 2.8 kW 220 Volt 50 Hertz* (in Indonesian), J. EECCIS, **1**, 1, pp. 1-6, 2007.
10. M.Q. Azeem, H.-ur Rehman, S. Ahmed, A. Khattak, *Design and analysis of switching in automatic transfer switch for load transfer*, International Conference on Open Source Systems and Technologies (ICOSST), Lahore, 15-17 Dec., 2016, pp. 129-134.
11. C.K. Amuzuvi, E. Addo, *A microcontroller-based automatic transfer switching system for a standby electric generator*, Ghana Mining Journal, **15**, 1, pp. 85-92, 2015.
12. A.F. Agbetuyi, A.A. Adewale, J.O. Ogunluyi, *Design and construction of an automatic transfer switch for a single phase power generator*, Int. J. of Engi. Science, **3**, 4, 2011.
13. B. Anto, *A low cost microcontroller-based automatic transfer switch for portable generator*, Proceedings SNPPTI, Jakarta, 28 April 2012, pp. 239-245.
14. C. Obasi, O.B. Odeyinde, J.J. Agidani, V.O. Ibiam, C.U., Osichinaka, *Design and implementation of microcontroller based programmable power changeover*, Computer Engineering and Intelligent Systems, **6**, 12, pp. 51-56, 2015.
15. A.P. Harahap, W. Dwiono, N. Harpawi, *SMS based power source switching hardware series* (in Indonesian), J. Elektronika Industri, **5**, pp. 40-49, 2010.
16. A.W. Indrawan, Hamdani, Nuraminah, *Design of ATS/AMF control and monitoring systems in the transfer of electric energy sources through the internet network* (in Indonesian), Proceedings SNTEI, PNUP, 3 IT_020, Makassar, 3 Nov., 2016 pp. 262-271.
17. R. Pakpahan, D.N. Ramadan, S. Hadiyoso, *Design and implementation automatic transfer switch (ATS) using Arduino Uno and Relay* (in Indonesian), J. Elektro Telekomunikasi Terapan, **3**, 2, pp. 332-341, 2016.
18. E.C. John, E.V. Chioma, O.V. Onyeka, *Single phase microcontroller-based automatic change over switch*, Int. J. of Electronics, Communication & Instrumentation Engineering Research and Development (IJECIERD), **8**, 1, pp. 7-16, 2018.
19. I.W. Suwardana, T.A. I Ketut, I.G.W.A. Kurniawan, *Automatic start control planning hydrant pump in Bali State Polytechnic* (in Indonesian), Jurnal Logic, **13**, 2, pp. 106-114, 2013.
20. Asriyadi, A.W. Indrawan, S. Pranoto, A.R. Sultan, R. Ramadhan, *Design of hybrid automatic transfer switch (ATS) system* (in Indonesian), Proc. SNTEI, Makassar, 3 Nov. 2016, pp. 408-414.
21. V. Croitoru, I.A. Tihon, O. Leonte, V. Ciocoiu, T. Voica, M. Aranghel, I. Vonica, *Data acquisition system based on mobile sensor networks*, Rev. Roum. Sci. Techn.– Électrotechn. et Énerg., **52**, 1, pp. 67-80, 2007.
22. S.L. Stănescu, V. Sava, P.D. Cristea, M.V. Udrea, *Firmware for laser surgical ophthalmic microscopes*, Rev. Roum. Sci. Techn.– Électrotechn. et Énerg., **55**, 4, p. 445-453, 2010.
23. S. Das, P.K. Sadhu, S. Chakraborty, S. Banerjee, T. Saha, *Design and implementation of an intelligent dual axis automatic solar tracking system*, Rev. Roum. Sci. Techn.– Électrotechn. et Énerg., **61**, 4, pp. 383-387 (2016).
24. B. Anton, A. Florescu, Ş.G. Roşu, *Standalone analog active cell-balancing circuit for automotive battery management systems*, Rev. Roum. Sci. Techn.– Électrotechn. et Énerg., **63**, 3, pp. 306-313, 2018.
25. V.-M. Placinta, F. Babarada, C. Ravariu, L.G. Alecu, *Digitally controlled electronic load for testing power supplies*, Rev. Roum. Sci. Techn.– Électrotechn. et Énerg., **64**, 2, pp. 131-136, 2019.
26. L. Breniuc, C.G. Haba, V. David, *embedded platform for developing medical applications*, Rev. Roum. Sci. Techn.– Électrotechn. et Énerg., **65**, 1-2, pp. 123-129, 2020.
27. National Standardization Body (BSN), SNI 0225, *General electrical installation requirements (PUIL) 2011, 8-21: Emergency (genset) generator installation*, ICS90.140.50, Jakarta, 2011, pp. 573-580.
28. IEC, *Electricity metering equipment (a.c.) – Particular requirements*, IEC 62053-21, 1st Ed., Geneva, pp. 19-32, 2003.
29. S.C. Chapra, *Applied numerical methods with MATLAB® for engineers and scientists*, 4th Ed., McGraw-Hill Education, New York, NY, USA, 2018, pp. 100-103.
30. P.T. PLN (Persero), *Standard Voltages*, SPLN 1, Jakarta, 1995, p. 5.