

HOME / About the Journal

## About the Journal

### Focus and Scope

The International Journal of Integrated Engineering (IJIE) is a single blind peer reviewed journal which publishes 3 times a year since 2009. The journal is dedicated to various issues focusing on 3 different fields which are:

**Civil and Environmental Engineering.** Original contributions for civil and environmental engineering related practices will be publishing under this category and as the nucleus of the journal contents. The journal publishes a wide range of research and application papers which describe laboratory and numerical investigations or report on full scale projects.

**Electrical and Electronic Engineering.** It stands as a international medium for the publication of original papers concerned with the electrical and electronic engineering. The journal aims to present to the international community important results of work in this field, whether in the form of research, development, application or design.

**Mechanical, Materials and Manufacturing Engineering.** It is a platform for the publication and dissemination of original work which contributes to the understanding of the main disciplines underpinning the mechanical, materials and manufacturing engineering. Original contributions giving insight into engineering practices related to mechanical, materials and manufacturing engineering form the core of the journal contents.

### Section Policies

#### Table of Contents

Open Submissions	Indexed	Peer Reviewed
------------------	---------	---------------

#### Articles

Open Submissions	Indexed	Peer Reviewed
------------------	---------	---------------

#### Editorial

Open Submissions	Indexed	Peer Reviewed
------------------	---------	---------------

### Publication Frequency

The International Journal of Integrated Engineering (IJIE) is published online with a frequency of three (3) issues per year. Besides that, special issues of *IJIE* will be published non-periodically from time to time.

### Open Access Policy

This journal provides immediate open access to its content on the principle that making research freely available to the public supports a greater global exchange of knowledge.

### Indexing and Abstracting

### MAKE A SUBMISSION

- Focus and Scope
- Editorial Board
- Guideline for Authors
- Indexing and Abstracting
- Publishing Ethics
- Copyright and License
- Open Access Policy
- Charge



Indexed by:



**Google Scholar**

**Scopus**

**Web of Science**

## **Publication Ethics and Malpractice Statement**

### **Publication Ethics and Malpractice Statement:**

#### **1. Editor Roles and Responsibilities**

The Editors and/or Editorial Board should:

- Review submitted manuscripts.
- Keep information pertaining to submitted manuscripts confidential.
- Disclose any conflicts of interest.
- Identify topics for special issues, which they may guest edit.
- Evaluate manuscripts only for their intellectual content without regard to race, gender, sexual orientation, religious belief, ethnic origin, citizenship, or political philosophy of the authors.
- Be responsible for making publication decisions for submitted manuscripts.
- Review suspected incidents of plagiarism.
- Advise on journal policy and scope.
- Attract new authors and submissions.

Editor Responsibilities toward Reviewers:

- Assigning papers for review appropriate to each reviewer's area of interest and expertise.
- Establishing a process for reviewers to ensure that they treat the manuscript as a confidential document and complete the review promptly.
- Informing reviewers that they are not allowed to make any use of the work described in the manuscript or to take advantage of the knowledge they gained by reviewing it before publication.
- Providing reviewers with written, explicit instructions on the journal's expectations for the scope, content, quality, and timeliness of their reviews to promote thoughtful, fair, constructive, and informative critique of the submitted work.
- Requesting that reviewers identify any potential conflicts of interest and asking that they recuse themselves if they cannot provide an unbiased review.
- Allowing reviewers appropriate time to complete their reviews.
- Requesting reviews at a reasonable frequency that does not overtax any one reviewer.
- Finding ways to recognize the contributions of reviewers, for example, by publicly thanking them in the journal; providing letters that might be used in applications for academic promotion; offering professional education credits; or inviting them to serve on the editorial board of the journal.

#### **2. Author and Corresponding Author Responsibilities**

Principles related to authorship with general consensus include the following:

- Individuals who contributed to the work but whose contributions were not of sufficient magnitude to warrant authorship should be identified by name in an acknowledgments section.
- All individuals who qualify for authorship or acknowledgment should be identified. Conversely, every person identified as an author or acknowledged contributor should qualify for these roles.
- Individuals listed as authors should review and approve the manuscript before publication.
- Editors should require authors and those acknowledged to identify their contributions to the work and make this information available to readers.
- The ultimate reason for identification of authors and other contributors is to establish accountability for the reported work.

Authorship should be limited to:

- Individuals who have made a significant contribution to the conception, design, execution, or interpretation of the reported study.
- Identification of authors and other contributors is the responsibility of the people who did the work (the researchers) not the people who publish the work (editors, publishers). Researchers should determine which individuals have contributed sufficiently to the work to warrant identification as an author.
- Individuals listed as authors should review and approve the manuscript before publication.
- Individuals who contributed to the work but whose contributions were not of sufficient magnitude to warrant authorship should be identified by name in an acknowledgments section.
- All individuals who qualify for authorship or acknowledgment should be identified. Conversely, every person identified as an author or acknowledged contributor should qualify for these roles.
- Those who have made significant contributions should be listed as co-authors.
- Others who have participated in certain substantive aspects of the research project should be acknowledged or listed as contributors.

The corresponding author should:

- Ensure that all appropriate co-authors have seen and approved the final version of the paper.
- Give consent to the manuscript submission for publication.
- Manage any requests to add, delete or rearrange author names in an article published in an online issue.

The authors should:

- The author-editor relationship is founded on confidentiality. Authors should hold all communication between themselves and the journal in confidence. Authors should designate a specific contact for all communication about the manuscript throughout peer review and (if accepted) the publication process. Authors should observe journal policy on communication with external peer reviewers (the policy may vary depending on whether a journal uses masked or non-masked peer review) and should observe journal policy on prepublication embargoes.
- Ensure that they have written entirely original works, and if the authors have used the work and/or words of others that this has been appropriately cited or quoted. The authors should provide a statement attesting to the originality of the study they have submitted for consideration. Originality is crucial, because many journals have limited space and editors may give a low priority to studies that, regardless of scientific accuracy and validity, do not advance the scientific enterprise. Some journals may ask authors to provide copies of reports on other studies (articles, manuscripts, and abstracts) related to the study under consideration.
- **Copyright Assignment.** Authors are usually expected to assign copyright to the journal publishing their study. Assignment of copyright is a legal document in which the authors assign certain rights to the publisher. Upon acceptance of an article, authors will be asked to complete a 'Journal Publishing Agreement'. An e-mail will be sent to the corresponding author confirming receipt of the manuscript together with a 'Journal Publishing Agreement' form or a link to the online version of this agreement.
- Secure the necessary reproduction rights with the rights holder for any third party material (images, digital content, etc.) you have used prior to submission.
- Ensure that they have acknowledged any funding that have contributed to the publication.
- Provide the raw data in connection with a paper for editorial review, and should be prepared to provide public access and retain such data for a reasonable time after publication.
- NOT in general publish manuscripts describing essentially the same research in more than one journal or primary publication.
- NOT submit the same manuscript to more than one journal concurrently constitutes unethical publishing behavior and is unacceptable.
- Include disclosure of all relationships that could be viewed as presenting a potential conflict of interest.
- Promptly notify the journal editor or publisher and cooperate with the editor to retract or correct the paper.
- Ensure that the manuscript contains a statement that all procedures were performed in compliance with relevant laws and institutional guidelines and that the appropriate institutional committee(s) has approved them.
- Include a statement in the manuscript that informed consent was obtained for experimentation with human subjects.
- Obtain appropriate consents, permissions and releases where an author wishes to include case details or other personal information or images of patients and any other individuals.

### 3. Peer-review Process

Reviewer responsibilities toward authors:

- Providing written, unbiased feedback in a timely manner on the scholarly merits and the scientific value of the work, together with the documented basis for the reviewer's opinion
- Indicating whether the writing is clear, concise, and relevant and rating the work's composition, scientific accuracy, originality, and interest to the journal's readers.
- Avoiding personal comments or criticism.
- Maintaining the confidentiality of the review process: not sharing, discussing with third parties, or disclosing information from the reviewed paper.

Reviewer responsibilities in regards to citations:

- Recommending the addition of important or relevant published works that are widely available into the citation list.
- Discouraging the citation of unrelated works.
- Alerting the authors on the possible errors or misuse of citations whenever necessary.
- Informing the authors on knowledge of cited works that have been updated or retracted.

Reviewer responsibilities toward editors:

- Notifying the editor immediately if unable to review in a timely manner and providing the names of potential other reviewers.
- Alerting the editor about any potential personal or financial conflict of interest and declining to review when a possibility of a conflict exists.
- Complying with the editor's written instructions on the journal's expectations for the scope, content, and quality of the review.
- Providing a thoughtful, fair, constructive, and informative critique of the submitted work, which may include supplementary material provided to the journal by the author.
- Determining scientific merit, originality, and scope of the work; indicating ways to improve it; and recommending acceptance or rejection using whatever rating scale the editor deems most useful.

- Noting any ethical concerns, such as any violation of accepted norms of ethical treatment of animal or human subjects or substantial similarity between the reviewed manuscript and any published paper or any manuscript concurrently submitted to another journal which may be known to the reviewer.
- Refraining from direct author contact.

#### 4. Publication Ethics

The Editorial Committee aims to shape the scientific journal environment such as ethical publishing practices, inform those involved in the editorial process, and foster informed decision-making by editors so the integrity of our publications is upheld. In addition, publishers and editors take reasonable steps to identify and prevent the publication of papers where research misconduct has occurred; in no event shall a journal or its editors encourage such misconduct, or knowingly allow such misconduct to take place; in the event that a journal's publisher or editors are made aware of any allegation of research misconduct the publisher or editor shall deal with allegations appropriately; the journal should have available guidelines for retracting or correcting articles when needed; and finally publishers and editors should always be willing to publish corrections, clarifications, retractions and apologies when needed.

#### 5. Copyright and Access

Authors who claim ownership to the data being reported, along with the manuscript's authors, may be asked to sign over certain publication rights to the journal through copyright transfer or a licensing agreement. Authors should be aware of, and must abide by, the terms of these agreements.

#### 6. Archiving

The International Journal of Integrated Engineering (IJIE) is published online with a frequency of three (3) issues per year. Besides that, special issues of *IJIE* will be published non-periodically from time to time.

#### Publisher

Penerbit UTHM as the publisher is committed to ensuring that advertising, reprint or other commercial revenue has no impact or influence on editorial decisions. In addition, Penerbit UTHM will assist in communications with other journals and/or publishers where this is useful to editors. Finally, Penerbit UTHM will work closely with other publishers and industry associations to set standards for best practices on ethical matters, errors and retractions—and are prepared to provide specialized legal review and counsel if necessary.

#### Copyright

Upon acceptance of an article, authors will be asked to complete a 'Journal Publishing Agreement'. An e-mail will be sent to the corresponding author confirming receipt of the manuscript together with a 'Journal Publishing Agreement' form or a [link to the online version of this agreement](#).

Subscribers may reproduce tables of contents or prepare lists of articles including abstracts for internal circulation within their institutions. If excerpts from other copyrighted works are included, the author(s) must obtain written permission from the copyright owners and credit the source(s) in the article. Publisher Office has preprinted forms for use by authors in these cases.

For open access articles: Upon acceptance of an article, authors will be asked to complete an 'Exclusive License Agreement'.

#### License

##### Open access licenses

Open Access is by licensing the content with a [Creative Commons \(CC\) license](#).

This work is licensed under a [Creative Commons Attribution-NonCommercial-ShareAlike 4.0 International License](#).

##### Publisher Office

Articles published under an Publisher Office user license are protected by copyright. Users may access, download, copy, translate, text and data mine the articles for non-commercial purposes provided that users:

- Cite the article using an appropriate bibliographic citation (i.e. author(s), journal, article title, volume, issue, page numbers, DOI and the link to the definitive published version)
- Maintain the integrity of the article
- Retain copyright notices and links to these terms and conditions so it is clear to other users what can and cannot be done with the article

- Ensure that, for any content in the article that is identified as belonging to a third party, any re-use complies with the copyright policies of that third party
- Any translations, for which a prior translation agreement with Publisher Office has not been established, must prominently display the statement: *"This is an unofficial translation of an article that appeared in an Publisher Office publication. Publisher Office has not endorsed this translation."*

For permission to use documents beyond permitted here, visit our website :

<http://penerbit.uthm.edu.my/ojs/>

This is a non commercial license where the use of published articles for commercial purposes is prohibited. Commercial purposes include:

- Copying or downloading articles, or linking to such postings, for further redistribution, sale or licensing, for a fee
- Copying, downloading or posting by a site or service that incorporates advertising with such content
- The inclusion or incorporation of article content in other works or services (other than normal quotations with an appropriate citation) that is then available for sale or licensing, for a fee
- Use of articles or article content (other than normal quotations with appropriate citation) by for-profit organizations for promotional purposes, whether for a fee or otherwise.

Use for the purposes of monetary reward by means of sale, resale, license, loan, transfer or other form of commercial exploitation.

### **Charge**

The Journal does not require any article processing charges (APC) or any article submission charges (ASC).

Paper offprints can be ordered via the offprint order form which is sent once the article is accepted for publication with chargers depending on pages required.

### **Address**

Authors should submit their manuscripts via the conference system, the online submission, peer-review and editorial system for International Journal of Integrated Engineering: <http://penerbit.uthm.edu.my/ojs/index.php/ijie>

### **Chief Editor:**

**Mechanical, Materials and Manufacturing Engineering.**

**Assoc. Prof. Ir. Ts. Dr Al Emran Ismail, Universiti Tun Hussein Onn Malaysia, Malaysia. Email : [emran@uthm.edu.my](mailto:emran@uthm.edu.my)**

**Civil and Environmental Engineering.**

**Assoc. Prof. Ir. Dr Riduan bin Yunus, Universiti Tun Hussein Onn Malaysia, Malaysia. Email : [riduan@uthm.edu.my](mailto:riduan@uthm.edu.my)**

**Ir. Dr Zainorizuan bin Mohd Jaini, Universiti Tun Hussein Onn Malaysia, Malaysia. Email : [rizuan@uthm.edu.my](mailto:rizuan@uthm.edu.my)**

**Electrical and Electronic Engineering.**

**Prof. Dr Mohammad Faiz Liew Abdullah, Universiti Tun Hussein Onn Malaysia, Malaysia. Email : [faiz@uthm.edu.my](mailto:faiz@uthm.edu.my)**

Journal Publication Office:

Director

Penerbit UTHM

Universiti Tun Hussein Onn Malaysia

86400 Parit Raja, Batu Pahat  
Johor Darul Ta'zim  
MALAYSIA

Tel : 07-453 7190  
Fax : 07-453 6145  
E-mail : [pt@uthm.edu.my](mailto:pt@uthm.edu.my)

©International Journal of Integrated Engineering (IJIE)

ISSN : 2229-838X e-ISSN : 2600-7916



This OJS site and its metadata are licensed under a [Creative Commons Attribution-NonCommercial-ShareAlike 4.0 International License](https://creativecommons.org/licenses/by-nc-sa/4.0/)



HOME / Indexing and Abstracting

## Indexing and Abstracting

IJIE is currently indexed by the following database:



MAKE A SUBMISSION

- Focus and Scope
- Editorial Board
- Guideline for Authors
- Indexing and Abstracting
- Publishing Ethics
- Copyright and License
- Open Access Policy
- Charge



Indexed by:



©International Journal of Integrated Engineering (IJIE)

ISSN : 2229-838X e-ISSN : 2600-7916



This OJS site and its metadata are licensed under a [Creative Commons Attribution-NonCommercial-ShareAlike 4.0 International License](https://creativecommons.org/licenses/by-nc-sa/4.0/)

HOME / ARCHIVES /

Vol. 12 No. 6 (2020): Special Issue: Electrical and Electronic Engineering

## Vol. 12 No. 6 (2020): Special Issue: Electrical and Electronic Engineering

PUBLISHED: 29-09-2020

### ARTICLES

#### Analysis of Electromagnetic Simulation Method for the Dielectric Lens Antenna

Farizah Ansarudin, Tharek Abd. Rahman, Yoshihide Yamada, Nurul Huda Abd Rahman 1-10

Abstract View 200

PDF 395

#### Band Rejections for WLAN and WIMAX Utilizing UWB Planar Antenna by Slits in the Conductor Elements

Siti Fatimah Jainal, Norliza Mohamed, Azura Hamzah 11-19

Abstract View 109

PDF 163

#### Fabrication of Human Body Phantom for Body Centric Communication Systems at 2.4 GHz

Nurul Najwa Mohd Nizam, Kamilia Kamardin, Yoshihide Yamada, Izni Husna Idris, Nurul Huda Abd Rahman, Hazilah Mad Kaidi 20-26

Abstract View 142

PDF 235

#### Security Features in Fingerprint Biometric System

Kamarul Zaman Panatik, Kamilia Kamardin, Siti Nurhafizza Maidin, Ngu War Hlaing, Irfanuddin Shafi Ahmed, Noureen Taj, Hazilah Mad Kaidi 27-39

Abstract View 165

PDF 242

#### Analysis on Wearable Antenna Performance on Different Radiating Elements for GPS Application

M.S. Amin Nordin, N. H. Abd Rahman, M. T. Ali, N. I. Zaidi, M. R. Ahmad 40-48

Abstract View 135

PDF 218

#### Realization of Circular Slot Frequency Selective Surfaces using Photoplotter and Wet Etching Technique for Terahertz Material Sensing Applications

N. S. Ishak, M. Hashim Dahri, N. A. Awang, W. Y. Chong, F. C. Seman 49-54

Abstract View 111

PDF 189

#### Internet of Things: A Monitoring and Control System for Rockmelon Farming

Hazilah Mad Kaidi, Norulhusna Ahmad, Rudzidatul Akmal Dziauddin, Norliza Mohamed, Liza Abdul Latiff, Sahnus Usman, Robiah Ahmad, Shamsul Sarip 55-61

Abstract View 330

PDF 733

#### Review of Switched Beamforming Networks for Scannable Antenna Application towards Fifth Generation (5G) Technology

Nazleen Syahira Mohd Suhaimi, Nor Muzlifah Mahyuddin 62-70

Abstract View 214

PDF 522

#### 5G Hairpin and Interdigital Bandpass Filters

Sahar Saleh, Widad Ismail, Intan Sorfina Zainal Abidin, Mohd Haizal Jamaluddin 71-79

Abstract View 231

PDF 467

#### Distribution Voltage in DC Micro-grid System based Solar PV Topologies Configuration in Sarawak, Malaysia

M. R. M. Sharip, D. K. A. Sakawi, D. N. Zaidel, P. R. P. Hoole, M. H. I. Saad, A. S. Abdullah, A. H. A. Karim, H. H. A. Halim, A. K. Rahman 80-86

MAKE A SUBMISSION

Focus and Scope

Editorial Board

Guideline for Authors

Indexing and Abstracting

Publishing Ethics

Copyright and License

Open Access Policy

Charge

Journals of  
 UTHM  
Universiti Tun Hussein Onn Malaysia

Indexed by:



 MYCITE  
malaysian citation index

 Google  
Scholar

 ASEAN  
CITATION  
INDEX

 publons

 Crossref

 EMERGING  
SOURCES  
CITATION  
INDEX



 ROAD



Abstract View 214

PDF 289

### Bandwidth Enhancement of 5G Parallel Coupled Line Band Pass Filter Using Patterned Ground Structure Technique

Ummi Haziqah Morshidi, Dyg Norkhairunnisa Abang Zaidel, Norhudah Seman, Melvin Philip Attan, Dayang Azra Awang Mat, Mohd Ridhuan Mohd Sharip, Haruichi Kanaya 87-93

Abstract View 125

PDF 187

### Design of Dumbbell Shaped DGS-Notch Patch Antenna for Microwave Imaging System

Chee Ka Chin, Dayang Azra Awang Mat, Mohamad Nizam Truna, Dyg Norkhairunnisa Abg Zaidel, H. Kanaya, Shafrida Sahrani, Kismet anak Hong Ping, Kuryati Kipli, Annie ak Joseph 94-104

Abstract View 130

PDF 299

### Accuracy and Reliability of Data in IoT System for Smart Agriculture

Nabilah Omar, Hushairi Zen, Nadia Nicole Anak Aldrin Anak Aldrin, Waluyo Waluyo, Febrian Hadiatna 105-116

Abstract View 368

PDF 813

### A Review of MRI Acute Ischemic Stroke Lesion Segmentation

Abang Mohd Arif Anaqi Abang Isa, Kuryati Kipli, Muhammad Hamdi Mahmood, Ahmad Tirmizi Jobli, Siti Kudnie Sahari, Mohd Saufee Muhammad, Soon K Chong, Buthainah Nawaf Issa Al-Kharabsheh 117-127

Abstract View 415

PDF 477

### Hybrid Wind Speed Prediction Model Using Intrinsic Mode Function (IMF) and Gradient Boosted Machine (GBM)

S. M. Lawan, W. A. W. Z. Abidin, M. Alhaji, M. K. Hasan, T. Masri 128-136

Abstract View 76

PDF 181

### Techno-economic Analysis of a Stand-alone Photovoltaic-Diesel Hybrid System for Rural Area in Sarawak

M. Harmen, N. Julai, A. K. Othman, H. Aznan, G. Kulanthaivel 137-147

Abstract View 194

PDF 460

### Designing a control system Based on SOC Estimation of BMS for PV-Solar System

Yonis M. Yonis Buswig, Ohirul Qays, Azuka Affam, Hani Albalawi, Al-Khalid Othman, Norhuzaimin Julai, Sim Sy Yi 148-157

Abstract View 241

PDF 432

### Wearable Coaching System

Nur Alia Athirah Hj Mohtadzar, Dyg Norkhairunnisa Abang Zaidel, Abdul Rahman Kram, Kasumawati Lias, Shahrol Mohamaddan, Mohamad Shaiful Abdul Karim, Yon Syafni Samat, Shigeru Takayama 158-164

Abstract View 126

PDF 247

### Five-Class SSVEP Response Detection using Common-Spatial Pattern (CSP)-SVM Approach

Mamunur Rashid, Norizam Sulaiman, Mahfuzah Mustafa, Bifta Sama Bari, Md Jahid Hasan 165-173

Abstract View 303

PDF 395

### Electroencephalogram (EEG) Human Stress Level Classification based on Theta/Beta Ratio

Tee Yi Wen, Nurul Aini Bani, Firdaus Muhammad-Sukki, Siti Armiza Mohd Aris 174-180

Abstract View 415

PDF 469

### Stair-Hexagonal Slot Antenna with Coplanar Waveguide Technique for Biomedical Applications

Yusnita Rahayu, M. Fadhlurrahman Hilmi, Yuyu Wahyu 181-188

Abstract View 150

PDF 290

### Palm Oil Soil Monitoring System for Smart Agriculture

Roziyani Rawi, Muhammad Shakhil Iman Hasnan, Aznida Abu Bakar Sajak 189-199

Abstract View 354

PDF 684

**Derivative Proportional – Integral Controller Using Nelder-Mead Optimization for Glycerine Purification Heating Process**

Zuriati Janin, Hazilah Mad Kaidi, Robiah Ahmad, Sheraz Khan

200-206

Abstract View 144

PDF 158

**IoT-Based Fire Safety System Using MQTT Communication Protocol**

Yuen Chark See , En Xiang Ho

207-215

Abstract View 479

PDF 1106

**Early Detection of Depression using Screening Tools and Electroencephalogram (EEG) Measurements**

Wong Hui Ming, Arifah Bahar, Khairul Radhi Bahar, Mitra Mohd. Addi

216-228

Abstract View 249

PDF 293

**Design and Implementation of Hybrid Active Power Filter (HAPF) for UPS System**

Mahendar Kumar, Zubair A Memon, M. Aslam Uqaili

229-238

Abstract View 151

PDF 287

**PWM Based VSC For Power Quality Assessment of Grid Integrated DFIG-WECS**

M.A Soomro, Z.A Memon, M. Kumar

239-252

Abstract View 147

PDF 198

**Power Electronic Converters for Single-Phase Grid Connected Photovoltaic System: An Overview**

Ghulam Mustafa Shoro, D. M. Akbar Hussain

253-264

Abstract View 134

PDF 276

**Optimal Placement of Shunt Capacitor in Distribution System by Particle Swarm Optimization**

Shahzor Ahmed, Mahesh Kumar, Amir Mahmood Soomro

265-272

Abstract View 141

PDF 416

**Performance Investigation of Dual Wavelength Fiber Laser using different SOAs**

Y. S. Ong, A. H. Sulaiman, F Abdullah, K. Y. Lau, N. Md. Yusoff Yusoff

273-281

Abstract View 432

PDF 220

©International Journal of Integrated Engineering (IJIE)

ISSN : 2229-838X e-ISSN : 2600-7916



This OJS site and its metadata are licensed under a [Creative Commons Attribution-NonCommercial-ShareAlike 4.0 International License](https://creativecommons.org/licenses/by-nc-sa/4.0/)



HOME / Editorial Team

## Editorial Team

### Editor-in-Chief

- Assoc. Prof. Ir. Ts. Dr. Al Emran Ismail, Universiti Tun Hussein Onn Malaysia
- Ir. Dr. Zainorizuan Mohd Jaini, Universiti Tun Hussein Onn Malaysia
- Prof. Dr. Mohammad Faiz Liew Abdullah, Universiti Tun Hussein Onn Malaysia
- Dr. Huda A Majid, Universiti Tun Hussein Onn Malaysia

### Managing Editor

- Ts. Dr. Norashidah Abd Rahman, Universiti Tun Hussein Onn Malaysia (Civil Engineering)
- Dr. Siti Nazahiyah Rahmat, Universiti Tun Hussein Onn Malaysia (Environmental Engineering)
- Dr. Mohd Azhar Harimon, Universiti Tun Hussein Onn Malaysia (Mechanical Engineering)
- Dr. Muhammad Faisal Mahmod, Universiti Tun Hussein Onn Malaysia (Mechanical Engineering)
- Dr. Nor Akmal Mohd Jamail, Universiti Tun Hussein Onn Malaysia (Electrical Engineering)
- Ts. Dr. Khalid Isa, Universiti Tun Hussein Onn Malaysia (Electrical Engineering)
- Dr. Rahmat bin Sanudin, Universiti Tun Hussein Onn Malaysia (Electrical Engineering)
- Dr. Norshidah Katiran, Universiti Tun Hussein Onn Malaysia (Electrical Engineering)
- Dr. Rohaida Mat Akir, Universiti Tun Hussein Onn Malaysia (Electrical Engineering)

### Advisory Board

- Prof. Dr. Yuntian Feng, Swansea University, United Kingdom (Computational Engineering)
- Prof. Dr. Ismail Bakar, Research Centre for Soft Soils, Malaysia (Geotechnical Engineering)
- Prof. Dr. Yoshimi Sonoda, Kyushu University, Japan (Structural Engineering)
- Prof. Dr. Agus Setyo Muntahor, Universitas Muhammadiyah Yogyakarta, Indonesia (Civil Engineering)
- Prof. Dr. Hideyuki Hasegawa, Toyama University, Japan (Medical Electronic Engineering)

### Editorial Team

- Dr. Norfaniza Mokhtar, Universiti Tun Hussein Onn Malaysia (Structural Engineering)
- Dr. Nurul Hidayah Mohd Kamarudin, Universiti Tun Hussein Onn Malaysia (Highway Engineering)
- Dr. Mohd Khaidir Abu Talib, Universiti Tun Hussein Onn Malaysia (Geotechnical Engineering)
- Dr. Nur Adila Ab. Aziz, Universiti Tun Hussein Onn Malaysia (Water Engineering)
- Dr. Siti Hidayah Abu Talib, Universiti Tun Hussein Onn Malaysia (Civil Engineering)

MAKE A SUBMISSION

Focus and Scope

Editorial Board

Guideline for Authors

Indexing and Abstracting

Publishing Ethics

Copyright and License

Open Access Policy

Charge



Indexed by:





This OJS site and its metadata are licensed under a [Creative Commons Attribution-NonCommercial-ShareAlike 4.0 International License](https://creativecommons.org/licenses/by-nc-sa/4.0/)



HOME / Contact

## Contact

IJIE Editorial Team, Universiti Tun Hussein Onn Malaysia

### Principal Contact

IJIE Editor

[ijie@uthm.edu.my](mailto:ijie@uthm.edu.my)

### Support Contact

Penerbit UTHM

**Phone**

+60-07-453 7194

[pt@uthm.edu.my](mailto:pt@uthm.edu.my)

### MAKE A SUBMISSION

Focus and Scope

Editorial Board

Guideline for Authors

Indexing and Abstracting

Publishing Ethics

Copyright and License

Open Access Policy

Charge



Indexed by:



©International Journal of Integrated Engineering (IJIE)

ISSN : 2229-838X e-ISSN : 2600-7916



This OJS site and its metadata are licensed under a [Creative Commons Attribution-NonCommercial-ShareAlike 4.0 International License](https://creativecommons.org/licenses/by-nc-sa/4.0/)

# International Journal of Integrated Engineering

## COUNTRY

Malaysia

 Universities and research institutions in Malaysia

## SUBJECT AREA AND CATEGORY

Engineering

- Civil and Structural Engineering
- Electrical and Electronic Engineering
- Industrial and Manufacturing Engineering
- Mechanical Engineering
- Mechanics of Materials

Materials Science

- Materials Science (miscellaneous)

## PUBLISHER

Penerbit UTHM

## H-INDEX

12

## PUBLICATION TYPE

Journals

## ISSN

2229838X

## COVERAGE

2017-2021

## INFORMATION

[Homepage](#)

[How to publish in this journal](#)

[ijie@uthm.edu.my](mailto:ijie@uthm.edu.my)

## SCOPE

The International Journal of Integrated Engineering (IJIE) is a single blind peer reviewed journal which publishes 3 times a year since 2009. The journal is dedicated to various issues focusing on 3 different fields which are:- Civil and Environmental Engineering. Original contributions for civil and environmental engineering related practices will be publishing under this category and as the nucleus of the journal contents. The journal publishes a wide range of research and application papers which describe laboratory and numerical investigations or report on full scale projects. Electrical and Electronic Engineering. It stands as a international medium for the publication of original papers concerned with the electrical and electronic engineering. The journal aims to present to the international community important results of work in this field, whether in the form of research, development, application or design. Mechanical, Materials and Manufacturing Engineering. It is a platform for the publication and dissemination of original work which contributes to the understanding of the main disciplines underpinning the mechanical, materials and manufacturing engineering. Original contributions giving insight into engineering practices related to mechanical, materials and manufacturing engineering form the core of the journal contents.

 Join the conversation about this journal

Civil and Structural Engineering				
Electrical and Electronic Engineering				
Industrial and Manufacturing Engineering				
Materials Science (miscellaneous)				
Mechanical Engineering				
Mechanics of Materials				

**FIND SIMILAR JOURNALS** ? options :

1  
**Jurnal Teknologi (Sciences and Engineering)**  
MYS

**33%**  
similarity

2  
**DYNA (Colombia)**  
COL

**31%**  
similarity

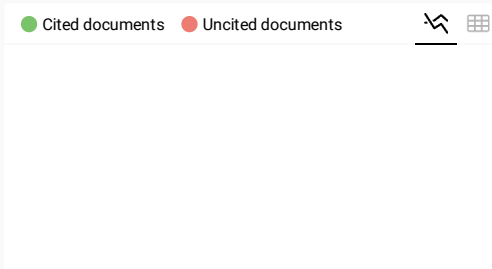
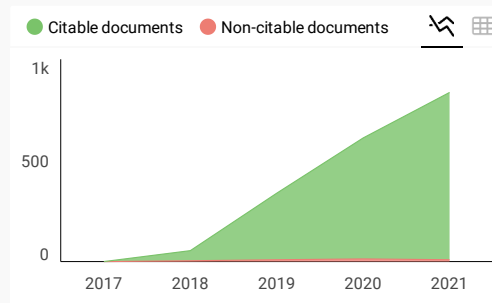
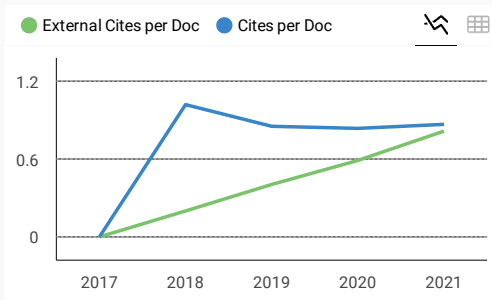
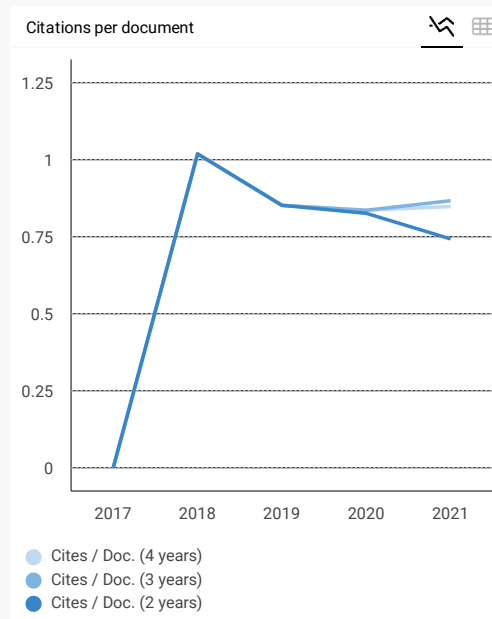
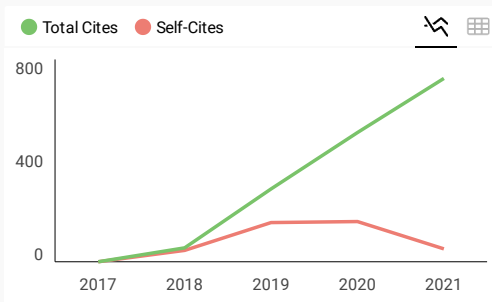
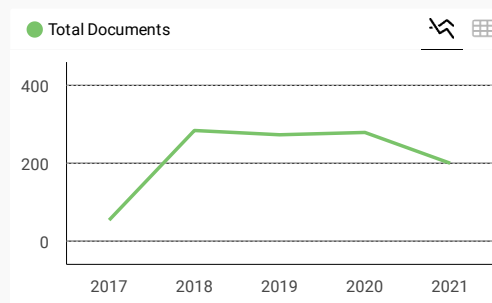
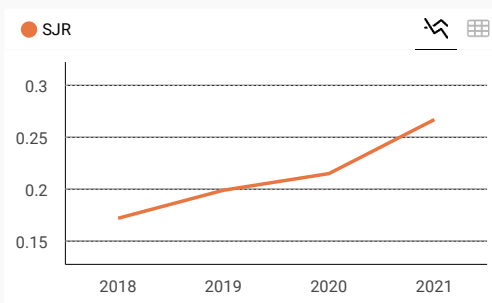

**International Journal of Integrated Engineering**

Q3 Civil and Structural Engineering  
best quartile

SJR 2021  
0.27

powered by scimagojr.com

← Show this widget in your own website

Just copy the code below and paste within your html code:

```
<a href="https://www.scimagojr.com" style="color: red; text-decoration: underline;">https://www.scimagojr.com
```

**SCImago Graphica**

Explore, visually communicate and make sense of data with our [new data visualization tool](#).

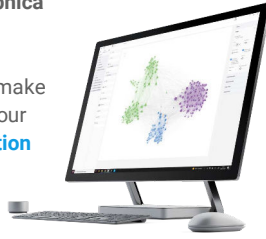

Metrics based on Scopus® data as of April 2022



**ABDUL WAHAB** 1 year ago

This journal is highly recommended for research article publication. The way they are dealing is really appreciated.

← reply



**Zeena** 5 months ago

Hi dear Abdul Wahab  
Can you please inform me the publication fees  
Thank you so much



**Melanie Ortiz** 1 year ago

SCImago Team

Dear Abdul, thanks for your participation! Best Regards, SCImago Team



**Abu** 1 year ago

Dear scimagojr  
You deserve nothing more than an apology. What is the point of this chat if you can't give a specific answer.

← reply



**Melanie Ortiz** 1 year ago

SCImago Team

Dear Abu,  
Thank you for contacting us. Could you please expand a little bit on your comment?  
We'll be glad to help you.  
Best Regards, SCImago Team



**Rajiv Srivastava** 2 years ago

This Journal run in very non professional way. Most of the time website is down, while submitting papers online system log out automatically.  
Even while Login website flashes a message wrong login id password  
Paper review remain pending for years, and no reply from editors while writing mails to them.  
Even Editors English is very poor, and they do not know how to write professional emails.  
All of sudden special issues are published, however no information is given at the website about special issue.

I advice you to contact Journal and review Journal indexing



Thanks and Regards

Rajiv Srivastava

← reply



**Melanie Ortiz** 2 years ago

SCImago Team

Dear Rajiv,  
thank you for your comment.  
Our data source is Scopus, SCImago doesn't participate in the journal's selection. SCImago has no authority to include or exclude SJR journals. We just show the data provided in the latest update by Scopus. Please contact Scopus Support regarding this matter here:  
[https://service.elsevier.com/app/answers/detail/a\\_id/14883/kw/scimago/supporthub/scopus/](https://service.elsevier.com/app/answers/detail/a_id/14883/kw/scimago/supporthub/scopus/)  
Best Regards, SCImago Team



**Roaa hamed** 2 years ago

Hi, I sent my paper to this Journal since 7 months and still in review stage, the editor didn't response to my e-mails What can I do?

← reply



**Melanie Ortiz** 2 years ago

SCImago Team

Dear Roaa,  
thank you for contacting us.  
We are sorry to tell you that SCImago Journal & Country Rank is not a journal. SJR is a portal with scientometric indicators of journals indexed in Elsevier/Scopus.  
Unfortunately, we cannot help you with your request, we suggest you keep contacting the journal's editorial staff , so they could inform you more deeply.  
Best Regards, SCImago Team



**Manjunatha M** 2 years ago

I would like to know whether this journal still under coverage or it will be out of the coverage until the end of 2020?

← reply



**SUMBO** 2 years ago

Never submit your hard work to this journal. They will just keep it with them and even don't care to send it for review. You cannot communicate the same as the editor won't respond to your email.



**Melanie Ortiz** 2 years ago

SCImago Team

Dear Manjunatha,  
Thank you very much for your comment.  
All the metadata have been provided by Scopus /Elsevier in their last update sent to SCImago, including the Coverage's period data. The SJR for 2019 was released on June 2020, 11. We suggest you consult the Scopus database directly to see the current index status as SJR is a static image of Scopus, which is changing every day.  
For further information, please contact Scopus support:  
[https://service.elsevier.com/app/answers/detail/a\\_id/14883/kw/scimago/supporthub/scopus/](https://service.elsevier.com/app/answers/detail/a_id/14883/kw/scimago/supporthub/scopus/)  
Best Regards, SCImago Team

K

**Kayam Thejaa** 2 years ago

Website is not working.  
Kindly request to rectify it

← reply



**Melanie Ortiz** 2 years ago

SCImago Team

Dear Kayam,

Thank you for contacting us. It seems it's working correctly.

Best Regards, SCImago Team

M

**Mahmoud Badreldien** 2 years ago

Hello  
Is the journal accept review papers?  
Also, is it accepts papers about micro grid and smart grid?  
Thanks

← reply



**Melanie Ortiz** 2 years ago

SCImago Team

Dear Mahmood,  
thank you for contacting us.

We are sorry to tell you that SCImago Journal & Country Rank is not a journal. SJR is a portal with scientometric indicators of journals indexed in Elsevier/Scopus.

Unfortunately, we cannot help you with your request, we suggest you visit the journal's homepage (See scope) or contact the journal's editorial staff , so they could inform you more deeply.

Best Regards, SCImago Team

R

**Rana Zaki** 2 years ago

I've submitted a paper to this journal since two months, until now it's not process for review stage or rejected

← reply



**Melanie Ortiz** 2 years ago

SCImago Team

Dear Rana,  
thank you for contacting us.

Unfortunately, we cannot help you with your request, we suggest you contact the journal's editorial staff , so they could inform you more deeply.

Best Regards, SCImago Team

M

**Manjunath M** 3 years ago

Dear Sir/Madam,

Why this journal website is not working.

← reply



**Melanie Ortiz** 2 years ago

SCImago Team

Dear Manjunath,

It seems it's working correctly.

Best Regards, SCImago Team



**ali** 3 years ago

Why the link of the journal website not works?

← reply



**Melanie Ortiz** 3 years ago

SCImago Team

Dear Ali,

It seems it's working correctly.

Best Regards, SCImago Team



**Karrar Alquraeny** 3 years ago

Dear SJR

I would like to know whether this journal still under coverage or it will be out of the coverage until the end of 2020?

I have noticed that the status has changed from on going to 2020 to many journals >> what does this mean ?

thank you very much

← reply



**MD SARFARAZ ALAM** 3 years ago

Dear Karrar

I have checked on SCOPUS website, this journal coverage till april 2020.

So, there is no issue

See the link

<https://www.scopus.com/sourceid/21100848408>



**Melanie Ortiz** 3 years ago

SCImago Team

Dear Karrar,

thank you very much for your comment, unfortunately we cannot help you with your request. We suggest you contact Scopus support:

[https://service.elsevier.com/app/answers/detail/a\\_id/14883/kw/scimago/supporthub/scopus/](https://service.elsevier.com/app/answers/detail/a_id/14883/kw/scimago/supporthub/scopus/)

Best Regards, SCImago Team

A

**Afnan Ahmad** 3 years ago

Dear Editor,

I recently submitted a journal article in this journal. I am here to know about the review period of this journal.

Thanks

[← reply](#)

S

**Sarfraz** 3 years ago

Dear afnan

In this journal reviewing period is very fast.

Within 3 months they will send complete reviews comments to you but article publication period is more because only 3 issues they are publishing in a year.

**Melanie Ortiz** 3 years ago

SCImago Team

Dear Afnan,

thank you for contacting us.

Sorry to tell you that SCImago Journal & Country Rank is not a journal. SJR is a portal with scientometric indicators of journals indexed in Elsevier/Scopus.

Unfortunately, we cannot help you with your request, we suggest you to visit the journal's homepage or contact the journal's editorial staff, so they could inform you more deeply.

Best Regards, SCImago Team

J

**JAIME LARUMBE** 3 years ago

Dears,

I would like to know if you are interested about an article about Systems Engineering/ Configuration Management.

Thanks,

Jaime

[← reply](#)**Melanie Ortiz** 3 years ago

SCImago Team

Dear Jaime,

thank you for contacting us.

Sorry to tell you that SCImago Journal & Country Rank is not a journal. SJR is a portal with scientometric indicators of journals indexed in Elsevier/Scopus.

Unfortunately, we cannot help you with your request, we suggest you to visit the journal's homepage or contact the journal's editorial staff, so they could inform you more deeply.

Best Regards, SCImago Team

M

**Misbah Ohag** 4 years ago

Dear Sirs

I want to send a research paper in this journal.

Please advise regarding the fees of publication and is it indexed by Scopus ?

Regards

Misbah

PhD student - UITM

[← reply](#)

P

**Pushpdant Jain** 3 years ago

There is no article processing fees for this journal



**Melanie Ortiz** 3 years ago

SCImago Team

Dear user, thanks for your participation! Best Regards, SCImago Team

M

**Mohanad Alaasam** 4 years ago

Dear Dr.

Can I publish my paper in your journal in electrical engineering .

Can you inform me about

1-the period of accepted the paper.

2-the cost of publishment .

Thank you

← reply

M

**Mohanad Alaasam** 4 years ago

Dear Dr.

Can I publish my paper in your journal in electrical engineering .

Can you inform me about

1-the period of accepted the paper.

2-the cost of publishment .

Thank you

← reply

M

**Mohanad Alaasam** 4 years ago

Dear Dr

Can I publish my paper in your journal .

So can you inform me the period of accepted the paper and the cost of publishment .

Thankyou

← reply



**Elena Corera** 4 years ago

SCImago Team

Dear Mohanad, in the link below you will find the information corresponding to the author's instructions of this journal. Best regards, SCImago Team

<http://penerbit.uthm.edu.my/ojs/index.php/ijie/information/authors>

#### Leave a comment

Name

Email

(will not be published)



I'm not a robot



reCAPTCHA  
Privacy - Terms

Submit

The users of Scimago Journal & Country Rank have the possibility to dialogue through comments linked to a specific journal. The purpose is to have a forum in which general doubts about the processes of publication in the journal, experiences and other issues derived from the publication of papers are resolved. For topics on particular articles, maintain the dialogue through the usual channels with your editor.

Developed by:



Powered by:



Follow us on [@ScimagoJR](#)

Scimago Lab, Copyright 2007-2022. Data Source: Scopus®

EST MODUS IN REBUS

Horatio (Satire 1.1, 106)

[Edit Cookie Consent](#)



# Source details

Check whether you can access Scopus remotely through your institution

[Maybe later](#) [Check access](#)

1.0

SJR 2021  
**0.267**

SNIP 2021  
**0.435**

## International Journal of Integrated Engineering

Scopus coverage years: from 2017 to 2022

Publisher: Penerbit UTHM

ISSN: 2229-838X

Subject area: [Materials Science: Materials Science \(miscellaneous\)](#) [Engineering: Industrial and Manufacturing Engineering](#)  
[Engineering: Mechanical Engineering](#) [Engineering: Electrical and Electronic Engineering](#) [View all](#)

Source type: Journal

[View all documents](#) [Set document alert](#) [Save to source list](#) [Source Homepage](#)

[CiteScore](#) [CiteScore rank & trend](#) [Scopus content coverage](#)

**i** Improved CiteScore methodology

CiteScore 2021 counts the citations received in 2018-2021 to articles, reviews, conference papers, book chapters and data papers published in 2018-2021, and divides this by the number of publications published in 2018-2021. [Learn more](#)

CiteScore 2021

$$1.6 = \frac{1,603 \text{ Citations 2018 - 2021}}{1,027 \text{ Documents 2018 - 2021}}$$

Calculated on 05 May, 2022

CiteScoreTracker 2022

$$1.3 = \frac{1,288 \text{ Citations to date}}{961 \text{ Documents to date}}$$

Last updated on 05 January, 2023 • Updated monthly

### CiteScore rank 2021

Category	Rank	Percentile
Materials Science		
Materials Science (miscellaneous)	#68/124	45th
Engineering		
Industrial and Manufacturing Engineering	#203/338	40th
Engineering		

[View CiteScore methodology](#) [CiteScore FAQ](#) [Add CiteScore to your site](#)

### About Scopus

- [What is Scopus](#)
- [Content coverage](#)
- [Scopus blog](#)
- [Scopus API](#)
- [Privacy matters](#)

### Language

- [日本語版を表示する](#)
- [查看简体中文版本](#)
- [查看繁體中文版本](#)
- [Просмотр версии на русском языке](#)

### Customer Service

- [Help](#)
- [Tutorials](#)
- [Contact us](#)

HOME / ARCHIVES /  
VOL. 12 NO. 6 (2020): SPECIAL ISSUE: ELECTRICAL AND ELECTRONIC ENGINEERING /  
Articles

## Accuracy and Reliability of Data in IoT System for Smart Agriculture

**Nabilah Omar**

Universiti Malaysia Sarawak

**Hushairi Zen**

Universiti Malaysia Sarawak

**Nadia Nicole Anak Aldrin Anak Aldrin**

Universiti Malaysia Sarawak

**Waluyo Waluyo**

Institut Teknologi Nasional

**Febrian Hadiatna**

Institut Teknologi Nasional

**Keywords:** Remote Monitoring, Smart Precise Agriculture, Internet of Things, Monitor Crop, Sensors Technology

### ABSTRACT

This paper presents the design and development of low-cost Internet of Things (IoT) system for remote monitoring of agriculture ecosystem. The aims of the research are to evaluate the accuracy and reliability of data collected and transmitted with developed IoT system and access from remote location. These data are then compared with the readings of the conventional stand-alone sensors or meters. The system is set in the laboratory and utilises low cost microcontroller, sensors, Wi-Fi network communication, cloud storage, mobile and web application. Microcontroller Arduino Uno ATmega328P is used with ESP8266 Wi-Fi module to enable the device to be connected to the Internet. The sensors used in this system are selected base on the plantâ€™s growth factor. All data collected from the sensors are sent to the Cloud platform such as ThingSpeak and Blynk. Periodical monitoring is carried out on laptop and mobile phone. The results showed that the data taken from the soil moisture, soil temperature, light intensity, surrounding temperature and humidity are accurate and reliable.

### DOWNLOADS

PDF 813

PUBLISHED

14-06-2020

### HOW TO CITE

Omar, N., Zen, H. ., Anak Aldrin, N. N. A. A., Waluyo, W., & Hadiatna, F. (2020). Accuracy and Reliability of Data in IoT System for Smart Agriculture. *International Journal of Integrated Engineering*, 12(6), 105–116. Retrieved from <https://publisher.uthm.edu.my/ojs/index.php/ijie/article/view/6390>

More Citation Formats ▾

### ISSUE

[Vol. 12 No. 6 \(2020\): Special Issue: Electrical and Electronic Engineering](#)

### SECTION

Articles

### LICENSE

#### Open access licenses

Open Access is by licensing the content with a [Creative Commons \(CC\) license](#).



This work is licensed under a [Creative Commons Attribution-NonCommercial-ShareAlike 4.0 International License](#).

### MAKE A SUBMISSION

Focus and Scope

Editorial Board

Guideline for Authors

Indexing and Abstracting

Publishing Ethics

Copyright and License

Open Access Policy

Charge



Indexed by:





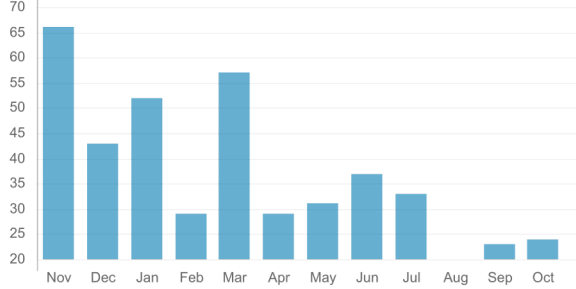

#### Most read articles by the same author(s)

- Sylvia Ong, Hushairi Zen, [Selection Combiner in Time-Varying Amplify Forward Cooperative Communication](#), [International Journal of Integrated Engineering; Vol. 13 No. 2 \(2021\); Special Issue 2021: Mechanical Engineering](#)

©International Journal of Integrated Engineering (IJIE)

ISSN : 2229-838X e-ISSN : 2600-7916



This OJS site and its metadata are licensed under a [Creative Commons Attribution-NonCommercial-ShareAlike 4.0 International License](#)





# Accuracy and Reliability of Data in IoT System for Smart Agriculture

Nabilah Binti Omar<sup>1</sup>, Hushairi Bin Zen<sup>1\*</sup>, Nadia Nicole Anak Aldrin<sup>1</sup>, Waluyo<sup>2</sup>, Febrian Hadiatna<sup>2</sup>

<sup>1</sup>Universiti Malaysia Sarawak (UNIMAS),  
Jalan Datuk Mohammad Musa, 94300 Kota Samarahan, Sarawak, MALAYSIA

<sup>2</sup>Institut Teknologi Nasional (ITENAS),  
Jl. PKH. Mustopha No.23, Bandung, 40124, INDONESIA

\*Corresponding Author

DOI: <https://doi.org/10.30880/ijie.2020.12.06.013>

Received 08 April 2020; Accepted 14 June 2020; Available online 02 July 2020

**Abstract:** This paper presents the design and development of low-cost Internet of Things (IoT) system for remote monitoring of agriculture ecosystem. The aims of the research are to evaluate the accuracy and reliability of data collected and transmitted with developed IoT system and access from remote location. These data are then compared with the readings of the conventional stand-alone sensors or meters. The system is set in the laboratory and utilises low cost microcontroller, sensors, Wi-Fi network communication, cloud storage, mobile and web application. Microcontroller Arduino Uno ATmega328P is used with ESP8266 Wi-Fi module to enable the device to be connected to the Internet. The sensors used in this system are selected base on the plant's growth factor. All data collected from the sensors are sent to the Cloud platform such as ThingSpeak and Blynk. Periodical monitoring is carried out on laptop and mobile phone. The results showed that the data taken from the soil moisture, soil temperature, light intensity, surrounding temperature and humidity are accurate and reliable.

**Keywords:** Remote Monitoring, Smart Precise Agriculture, Internet of Things, Monitor Crop, Sensors Technology

## 1. Introduction

Sarawak is the largest state in Malaysia with 124,499 km<sup>2</sup> land area which made up 37.5 % of Malaysia [1]. Despite having huge landmass, Sarawak's agriculture sector is under develop. Agriculture-based food products are mostly imported from the outside, making Sarawak one of the largest food importer [2]. Sarawak is not ready to become food exporter due to low farm productivity [3]. Lack of human labour, continuous use of traditional farming methods and no effective supply chain networks are the major hurdle to the agriculture sector. Current scenario for agriculture sector is based on traditional farming, which is far from sustainable agriculture principle. Traditional farming causes environmental pollution which eventually lowering the farm productivity [2].

To improve agricultural productivity, the crop performance under different growth ecosystems such as soil conditions, soil nutrients level and environment are vital to recognised [4]. As for that reason, farmers must implement new innovative agriculture practise namely as smart agriculture or smart farm. Smart agriculture utilised Internet of Things (IoT) technology. IoT term was first coined in 1999 which describe a system where the internet is connected to the physical world via universal sensors [5]. Internet of Things (IoT) is a hot concept newly emerged that will influence how farmers manage and pursue modern farming. IoT provides automation and wireless communication between devices to devices. IoT is made possible due to the decrease of cost of technologies such as cellular network, smartphones, short range wireless communication, and sensors. IoT carry out smart function that are not able to be performed efficiently by human.

\*Corresponding author: [zhushair@unimas.my](mailto:zhushair@unimas.my)

Real time continuous monitoring, accurate information and automation can be executed reliably with IoT. Basic IoT architecture include microcontroller unit, network connectivity, sensor module, memory and user interface [6]. In farming context, the plant will be embedded with sensors, connected with network connectivity, cloud storage and mobile application.

The objective of this smart monitor system is to develop a simple, inexpensive and reliable system utilising sensor, microcontroller unit, network communication and mobile or web application. From this system, farmers can monitor their crop remotely, collect data from their crop and finally use the data to determine the threshold value which can be used for designing smart agriculture practices.

## 2. Literature Review

Every single aspect of Smart Agriculture is discussed in [7]. The article discusses the key drivers of technology in agriculture, also what are the barriers, major smart agriculture applications, future practices and current technology. From the article, farmer's motivations in implementing IoT in agriculture are to reduce climate effects and to achieve higher yields, optimised resources and automation. Inexpert manpower, expensive, and lack of connectivity coverage are few examples of the barrier in executing IoT in agriculture. Soil condition monitoring, smart irrigation, zero fertiliser waste, pest and disease management are the discussed smart agriculture applications.

Smart farming based on remote monitoring are becoming more famous. The goal of [8] is to create farm-environment monitoring system using Arduino Yun as microcontroller unit with Wi-Fi connection. Sensing result can be seen on JavaScript-based browsers. Video cameras are installed to view real-time crop growth. This smart environment monitoring system is reliable in terms of safety. The data is safely stored inside localhost and real-time viewing is possible.

In [9] the research aims to design smart micro farm to monitor Algae spirulina growth. It uses a microcontroller, such as Arduino, and sensors to create a real-time monitoring system via the internet to monitor water temperature, ultraviolet intensity, and water turbidity. Sensors used in this research are DS18B20 temperature sensor, ML8511 UV sensor and SEN0189 turbidity sensor. All sensors give voltage output measurement. From the voltage outputs, the readings are then analysed accordingly. This system can perform smart automation accordingly when sensor reading meets requirement.

Project was carried out in [10] to study the smart farm monitoring on environment at paddy warehouse. The prototype of a smart capsule was developed to measure the humidity in paddy bags stored in various locations within a warehouse. The smart capsule used Node MCU ESP8266 microcontroller and the SHT21 humidity sensor to send data to the Blynk server over a Wi-Fi network. This monitoring system can perform systematic data storage and effectively display all data.

IoT-based Smart Garden with Weather Station system, which can be used to monitor the growth of plant every day and predict the probability for raining was introduced in [11]. The system was equipped with a sensors and actuators, where it can be monitored and controlled by using a smartphone. Sensors used in this system are DHT11 temperature and humidity sensor, LDR, soil moisture sensor and barometric pressure module sensor. Values from sensors such as temperature, humidity and barometric pressure are compared with online value. From the comparison, it is assumed that the sensors from this smart garden system are working accurately.

In [12], a new system is implemented for smart farming called 'connected farm'. Connected farm systems provide smartphone application to monitor and control the connected farm. Sensors collected data such as the soil moisture, temperature and carbon dioxide monitoring from the farm. The data can be access through the apps and any issue arise, an alert is sent to the farmer. The apps include farm control. Through farm control, farmers can react to the alert sent. For example, if the soil moisture sensor uploads a value less than a threshold suggested by the knowledge base, farmer can trigger the irrigation system using farm control. Besides that, experienced farmers can share their knowledge and guidance with others. Knowledge such as optimal growth conditions can be easily accessed through the apps.

## 3. Methodology

The methodology section is summarised into four parts. The first part discusses the conceptual design and flow. The second and third part focuses on the hardware and software connection while the final part introduces the farm meter used in this system.

### 3.1 Conceptual Design and Design Flow

Crucial parameters that affect the plant growth are light, water, temperature and nutrients [13]. Water is vital for plant's survival. Water in soil (soil moisture) can affect the nutrient uptake and root's growth. While water vapour in air (humidity), is required for photosynthesis. Beside humidity, light and temperature are also essential for photosynthesis [14]. Therefore, parameters such as light, water and temperature are stressed in the monitoring system.

To monitor the parameters, sensors are put at two places of the plant and categorised as two group. The two groups are surrounding weather and soil conditions. The first group of sensors will be collecting data of surrounding

weather of the farm. For this group, sensor such as temperature sensor, humidity sensor and light sensor are used. Second group will exclusively monitor soil condition. This group will use sensor such as soil temperature sensor and soil moisture sensor. The conceptual design for this system is shown as in Figure 1.

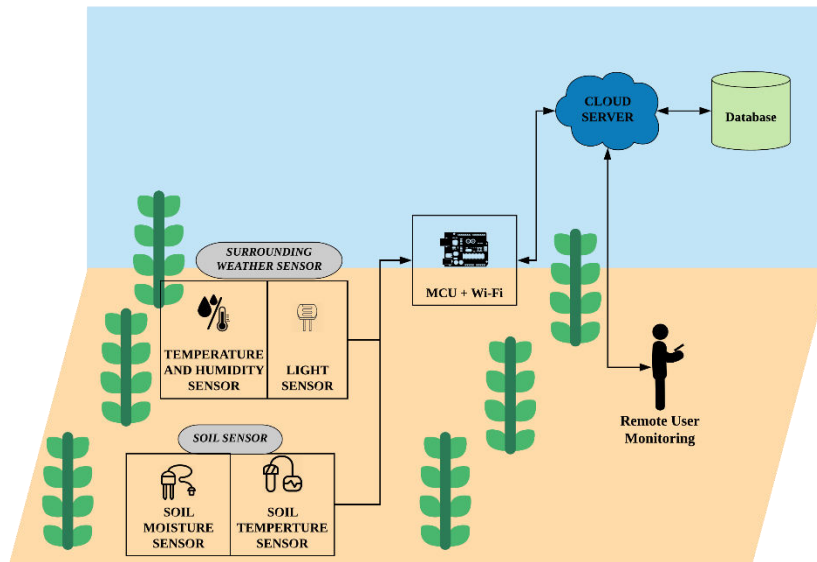

Fig. 1 - Conceptual design

Figure 2 shows the overall system’s flow. There will be two sensor nodes for this system. All these sensors will be connected to Arduino Uno ATmega328P with ESP8266 Wi-Fi module. ESP8266 Wi-Fi module is used to connect all sensors online. All the sensors data can be monitor through two platform, ThingSpeak and Blynk. At the same time, all data will be store in database and can be downloaded as a CSV file.

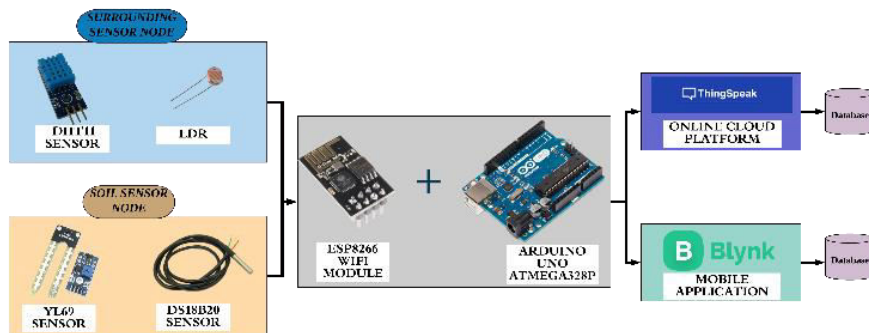
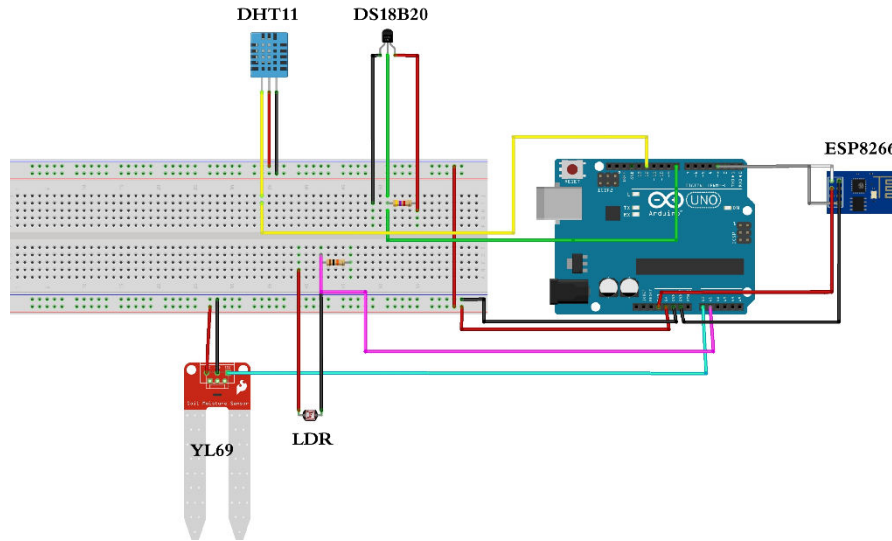

Fig. 2 - System's Flow

### 3.2 Hardware

Figure 3 shows the overall system’s hardware connection. Arduino Uno with ATmega328P microchip is a used as microcontroller unit. The Arduino Uno ATmega328P contain two part. The two part are the hardware part and software part. The hardware is the Arduino Uno board. The board has 14 digital input pins and 6 analogue input pins. The software part is the Arduino Integrated Development Environment (IDE) which use language like C programming language [15]. To connect the hardware to the internet and send data from microcontroller to the cloud, ESP8266 Wi-Fi module is used. ESP 8266 connects with the microcontroller using AT commands whereas the microcontroller communicates with the ESP 8266 using UART with definite Baud rate [16].



**Fig. 3 - Hardware Connection**

Two sensor nodes are categorised. First node is to monitor soil condition, two sensors are used. The two sensors are DS18B20 temperature sensor with waterproof probe and YL69 soil moisture sensor. YL69 soil moisture measure the resistance of electrical conductivity of water. Moist soil conducts electricity better than dry soil. The higher the conductivity, the lower the resistance. Hence, the reading relies on the water content in the soil [17].

Second node will monitor surrounding condition. Two sensors used are DHT11 and LDR. DHT11 sensor is used to monitor temperature and humidity. LDR is for light intensity monitoring. DHT11 sensor make use a thermistor to sense the temperature and humidity module to measure the humidity [18]

### 3.3 Software

#### 3.3.1 ThingSpeak

ThingSpeak is an IoT analytics platform service that allows user to aggregate, visualise and analyse live data streams in the cloud. Instant visualisations of data are posted to ThingSpeak instantly from smart connected devices [19].

For ThingSpeak, user needed to create a channel and select how many chart fields are used. For this system, five fields are created. Using both ThingSpeak and Blynk is easy. From Blynk, a widget call “webhook” is used to “hook” both platforms together. When sensors send data to Blynk, it will simultaneously send data to ThingSpeak. In webhook setting, the ThingSpeak channel API is set to hook both platforms.

#### 3.3.2 Blynk

Blynk is an IoT platform that allows to control, interact and monitor IoT devices such as Arduino, Raspberry Pi, ESP8266 and many more. A graphic interface of the project can be built simply by dragging and dropping widgets [20].

Through this app, all sensors value will be display. Figure 4 shows the application interface in editor mode. All the widget used is as shown in Figure 4. Values such as humidity, soil moisture, temperature and soil temperature are shown in ‘super chart’ widget while LDR value are shown in “display value” widget.

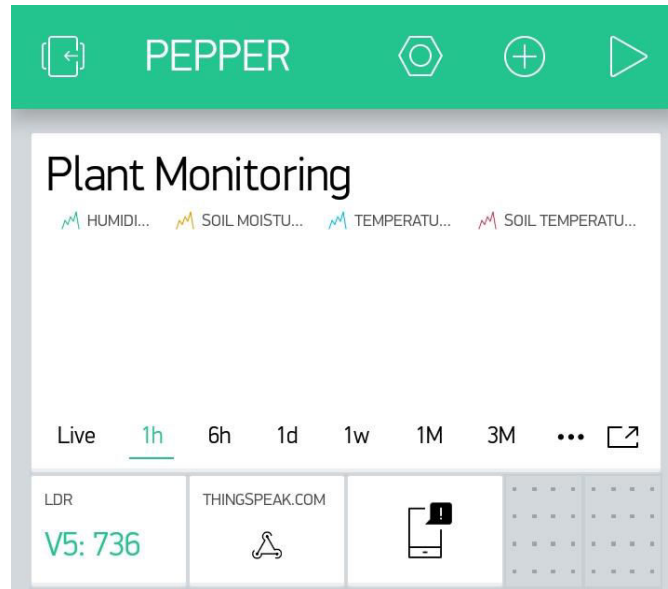

**Fig. 4 - Blynk App Interface in Editor Mode**

Other widgets used are ‘webhook’ widget and ‘notification’ widget. Webhook use to connect both Blynk and ThingSpeak together. Notification widget will help to notify user when hardware device is offline.

### 3.4 Farm meter

All the sensors are calibrated, and the accuracy of the values are compared with generic agriculture meter available as shown in Figure 5. Soil meter can measure three values such as soil moisture, light Lux level, and pH value. Digital thermo-hygrometer measure temperature and humidity level. Digital thermometer with waterproof probe also used to compare soil temperature.



**Fig. 5 - Soil meter, digital thermo-hygrometer and digital thermometer respectively**

## 4. Results and Discussions

In this section, the device, web and mobile application performances are analysed and summarised in two part. The first part discusses on software’s visualisation and application. Second part focuses on accuracy and data reliability.

### 4.1 ThingSpeak

Figures 6 (a), 6(b) and 6 (c) show the visualisation in ThingSpeak. Last field shows the LDR value in numeric display which is to replicate Blynk “display value” widget.



Fig. 6 (a) ThingSpeak Visualisation



Fig. 6 (b) ThingSpeak Visualisation



Fig. 6 (c) - ThingSpeak Visualisation



Data collected from the sensors are stored in ThingSpeak database. In ThingSpeak platform, data is retrieved by exporting csv file from the website. Figure 7 shows the example of the data exported from ThingSpeak. The sensors data is updated with 5 minutes interval.

	A	B	C	D	E	F	G
1	created_at	entry_id	field1	field2	field3	field4	field5
2	2019-07-02 11:50:23 +08	1	/pin[0]/	/pin[1]/	/pin[2]/	/pin[3]/	/pin[4]/
3	2019-07-02 11:57:57 +08	2	0	0	34.8	27.25	831
4	2019-07-02 12:02:58 +08	3	0	0	36.168	27.25	837
5	2019-07-02 12:07:58 +08	4	0	0	38.123	27.25	836
6	2019-07-02 12:12:58 +08	5	0	0	39.003	27.188	844
7	2019-07-02 12:17:58 +08	6	0	0	40.274	27.25	853
8	2019-07-02 12:22:58 +08	7	0	0	41.056	27.188	852
9	2019-07-02 12:27:59 +08	8	0	0	39.98	27.188	844
10	2019-07-02 12:32:59 +08	9	0	0	40.274	27.188	854
11	2019-07-02 12:37:59 +08	10	0	0	41.838	27.313	839
12	2019-07-02 12:43:00 +08	11	0	0	42.326	27.25	819
13	2019-07-02 12:48:00 +08	12	0	0	42.62	27.25	829
14	2019-07-02 12:53:00 +08	13	0	0	43.109	27.313	824
15	2019-07-02 12:58:00 +08	14	0	0	42.522	27.313	815
16	2019-07-03 11:00:16 +08	15	0	0	26.295	27.625	809
17	2019-07-03 11:05:16 +08	16	0	0	30.108	27.625	819
18	2019-07-03 11:10:16 +08	17	0	0	32.454	27.625	809
19	2019-07-03 11:15:16 +08	18	0	0	34.506	27.75	818
20	2019-07-03 11:20:16 +08	19	0	0	34.409	27.688	815
21	2019-07-03 11:25:17 +08	20	0	0	35.093	27.688	813
22	2019-07-03 11:30:17 +08	21	0	0	35.582	27.75	786
23	2019-07-03 11:35:17 +08	22	0	0	36.07	27.75	808
24	2019-07-03 11:40:17 +08	23	0	0	36.461	27.688	821
25	2019-07-03 11:47:37 +08	24	0	0	37.439	27.688	816
26	2019-07-03 11:52:37 +08	25	0	0	38.123	27.75	818
27	2019-07-03 11:57:38 +08	26	0	0	38.416	27.75	839

Fig. 7 - The example of data collected in ThingSpeak database

## 4.2 Blynk

The Blynk mobile application was able to display the status of each hardware device as shown in Figure 8. The "online" status showed that the device work normally while the "offline" status indicated that the device losing Internet connection. A notification would be sent in case any device was disconnected from the system. Once there was an offline device, the Blynk application would send an alert message as shown in Figure 9.

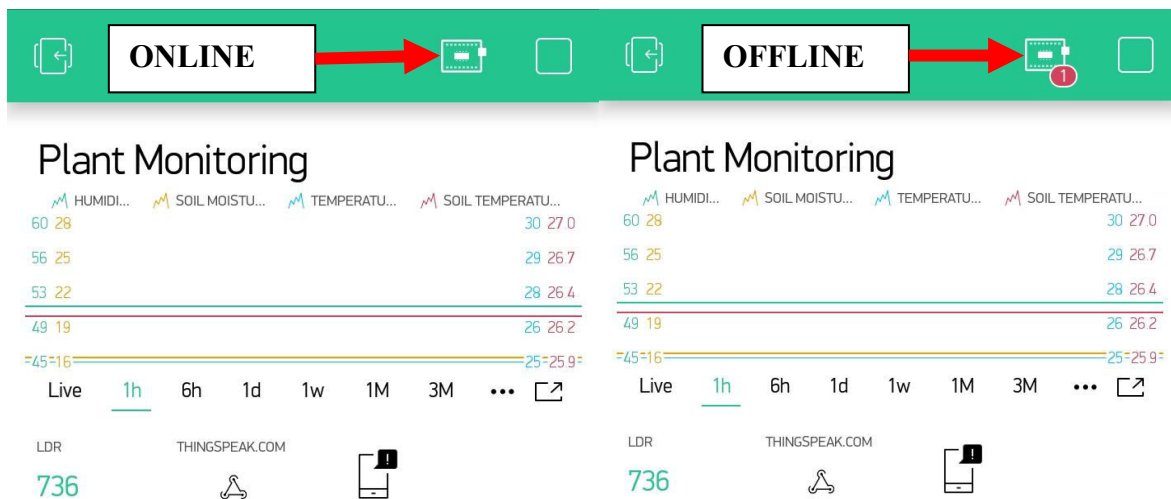
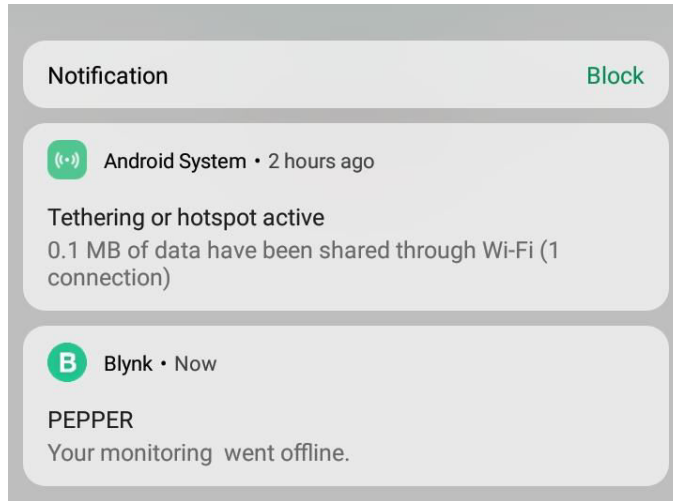

Fig. 8 - Blynk Hardware Status





**Fig. 9 - Example of Notification system**

For Blynk Application, the data from “super chart” widget is emailed by selecting the “export to csv” option. Figure 10 shows the example of the data downloaded from Blynk. Blynk cloud is free to use but limited by data rate. For this system, Blynk records data from sensor with interval of 5 minutes.

A	B	C	D	E	F	G
Epoch time	Time GMT	Time UTC +8	Humidity (V1)	Soil Moisture (V3)	Temperature (V2)	Soil Temperature(V4)
1562039820	2/7/2019 3:57	2/7/2019 11:57	57	34.8	29	27.25
1562040120	2/7/2019 4:02	2/7/2019 12:02	55	36.168	29	27.25
1562040420	2/7/2019 4:07	2/7/2019 12:07	55	38.123	29	27.25
1562040720	2/7/2019 4:12	2/7/2019 12:12	58	39.003	29	27.188
1562041020	2/7/2019 4:17	2/7/2019 12:17	54	40.274	29	27.25
1562041320	2/7/2019 4:22	2/7/2019 12:22	58	41.056	29	27.188
1562041620	2/7/2019 4:27	2/7/2019 12:27	53	39.98	29	27.188
1562041920	2/7/2019 4:32	2/7/2019 12:32	58	40.274	29	27.188
1562042220	2/7/2019 4:37	2/7/2019 12:37	54	41.838	29	27.313
1562042520	2/7/2019 4:42	2/7/2019 12:42	58	42.326	29	27.25
1562042820	2/7/2019 4:47	2/7/2019 12:47	58	42.62	29	27.25
1562043120	2/7/2019 4:52	2/7/2019 12:52	56	43.109	29	27.313
1562043420	2/7/2019 4:57	2/7/2019 12:57	53	42.522	29	27.313
1562122800	3/7/2019 3:00	3/7/2019 11:00	62	26.295	29	27.625
1562123100	3/7/2019 3:05	3/7/2019 11:05	61	30.108	29	27.625
1562123400	3/7/2019 3:10	3/7/2019 11:10	60	32.454	29	27.625
1562123700	3/7/2019 3:15	3/7/2019 11:15	59	34.506	31	27.75
1562124000	3/7/2019 3:20	3/7/2019 11:20	59	34.409	32	27.688
1562124300	3/7/2019 3:25	3/7/2019 11:25	60	35.093	28	27.688
1562124600	3/7/2019 3:30	3/7/2019 11:30	59	35.582	29	27.75
1562124900	3/7/2019 3:35	3/7/2019 11:35	59	36.07	29	27.75
1562125200	3/7/2019 3:40	3/7/2019 11:40	60	36.461	28	27.688
1562125620	3/7/2019 3:47	3/7/2019 11:47	60	37.439	28	27.688
1562125920	3/7/2019 3:52	3/7/2019 11:52	59	38.123	29	27.75
1562126220	3/7/2019 3:57	3/7/2019 11:57	59	38.416	29	27.75
1562126520	3/7/2019 4:02	3/7/2019 12:02	59	38.416	29	27.75

**Fig. 10 - The example of data collected from Blynk database**

### 4.3 Data accuracy and reliability

The reading differences between the farm meters and sensors are summarised in Table 1 and Table 2 respectively.

Table 1 shows the comparison between farm meter and sensor for soil condition. Soil meter measure soil moisture in ten level and mark as dry (level 1) to wet (level 10) correspondingly. The YL69 soil moisture sensor measure in moisture percentage. From the table, it is only assumed that level 1 is about 10%. The soil meter read level 3 for all readings while soil moisture sensor reads between 30-36%. Therefore, there is no absolute way to tell the sensor's accuracy.

The average temperature difference between digital thermometer and DS18B20 is found out to be  $\pm 0.5^{\circ}\text{C}$ . The difference between the digital thermometer and sensor are insignificant and almost similar. Then it can be assumed that the sensor is working properly.

Table 2 shows the difference between farm meter and sensor for the surrounding weather node. The average temperature difference between digital thermo-hygrometer and DHT11 is  $\pm 0.7^{\circ}\text{C}$ . The average temperature difference between the thermo-hygrometer and DHT11 is considered small. The small difference is due to DHT11 measures temperature in positive integer which ranging from 0 to  $50^{\circ}\text{C}$ .

The average humidity difference between digital thermo-hygrometer and DHT11 is  $\pm 25\%$ . The reading variance between the sensor and digital thermo-hygrometer reading is due to different humidity measurement range. DHT11 can only measure relative humidity level ranging from 20% to 80%. However, digital thermo-hygrometer can measure relative humidity between 0 to 100%. For better result and comparison, DHT sensor type DHT22 should be used instead. DHT22 can measure relative humidity between 0 to 100% which is same with digital thermo-hygrometer.

**Table 1 - Reading differences between generic meter and Soil Condition Sensors Node**

Date/Time	Soil Meter, Soil Moisture (Level)	YL69 Sensor, Soil Moisture (%)	Digital Thermo- Temp ( $^{\circ}\text{C}$ )	DS18B20 sensor, Temp ( $^{\circ}\text{C}$ )
100719/1030	3.5	36.4	27.7	27.1
100719/1130	3	34.7	27.8	27
100719/1230	3	34.7	27.9	27.1
100719/1430	3	34.4	27.9	27.2
100719/1530	3	34.9	28	27.4
100719/1630	3	34.8	28.1	27.5
110719/1030	3	30.8	27.3	26.7
100719/1130	3	32.9	26.1	25.8
110719/1230	3	32.6	26.7	26.2
110719/1330	3	31.7	27.1	26.6
110719/1430	3	32	27.2	26.7
110719/1530	3	31.4	27.3	26.7
110719/1630	3	31.9	27.3	26.7

**Table 2 - Reading differences between generic meter and surrounding weather sensor node**

Date/ Time	Digital Thermo-hygrometer, Temp (°C)	DHT11 sensor, Temp (°C)	Digital Thermo-hygrometer, Hum (%)	DHT11 sensor, Hum (%)
100719/1030	28.8	28	73	48
100719/1130	29	28	69	45
100719/1230	29.3	29	69	44
100719/1430	29.2	28	66	41
100719/1530	29.6	29	61	38
100719/1630	29.5	30	62	39
110719/1030	27.9	28	75	47
100719/1130	28.1	28	76	48
110719/1230	28.7	28	79	53
110719/1330	28.8	28	78	51
110719/1430	28.6	28	77	52
110719/1530	28.4	28	77	48
110719/1630	28.4	28	75	47

## 5. Conclusions

This monitoring system utilised inexpensive sensor technology with Arduino Uno as microcontroller with open ware platform such as Blynk and ThingSpeak. The monitoring can be easily done by using Blynk mobile application and ThingSpeak web applications. The system is tested with generic agriculture meters and resulted an accurate and reliable system. This monitoring system can help farmer monitor their farm in real time and provide reliable data. Monitoring systems helps farmer to gather data needed to monitor plant's health. All the data collected and store in ThingSpeak database can be further utilised for data analytics.

## Acknowledgement

Author would like to express gratitude to the Sarawak Multimedia Authority (SMA) for the supports and the funding given for this project under Centre of Excellence (CoE) Grant. Also, thanks to Department of Electricals and Electronics, Faculty of Engineering, Universiti Malaysia Sarawak (UNIMAS).

## References

- [1] Sarawak State Secretary, "Sarawak Government Official Portal," [Online]. Available: [https://www.sarawak.gov.my/web/home/article\\_view/159/176/](https://www.sarawak.gov.my/web/home/article_view/159/176/). [Accessed 26 September 2019].
- [2] Islam, M.S., & Lamoh, M.M. (2017). *Advanced Eco-Farming Technology to Achieve Sustainable Agricultural Growth in Sarawak*. Kota Samarahan, Sarawak: UNIMAS Publisher.
- [3] Pei Pei, G. (2018). Sarawak not ready to export food products on large scale to China. *The New Straits Times*. [online] Available at: <https://www.nst.com.my/news/nation/2018/09/413186/sarawak-not-ready-export-food-products-large-scale-china> [Accessed 26 Sep. 2019].
- [4] Bhagat, M., Kumar, D., & Kumar, D. (2019). *Role of Internet of Things (IoT) in Smart Farming: A Brief Survey. 2019 Devices for Integrated Circuit (DevIC)*. Kalyani, India.
- [5] Ashton, K. (2009). That 'Internet of Things' Thing, *RFID Journal*, vol. 22, no. 7, pp. 97–114, July 2009.
- [6] Hassan, Q.F. (2018). *Internet of Things A to Z: Technologies and Applications*. John Wiley & Sons, Inc. Hoboken, New Jersey.
- [7] Ayaz, M., Ammad-Uddin, M., Sharif, Z., Mansour, A., & Aggoune, E.H.M. (2019). *Internet-of-Things (IoT)-Based Smart Agriculture: Toward Making the Fields Talk*. *IEEE Access*, vol. 7, p. 33.
- [8] Tsai, C.F., Liang, T.W. (2018). *Application of IoT Technology in The Simple Micro-Farming Environmental*. 2018 IEEE International Conference on Advanced Manufacturing (ICAM). Yunlin, Taiwan.
- [9] Ariawan, E., & Makalew, S.A. (2018). *Smart Micro Farm: Sustainable Algae Spirulina Growth*. 2018 10th International Conference on Information Technology and Electrical Engineering (ICITEE). Kuta, Indonesia.

- [10] Serikul, P., Nakpong, N., & Nakjuatong N. (2018). Smart Farm Monitoring via the Blynk IoT Platform: Case Study: Humidity Monitoring and Data Recording. 2018 16th International Conference on ICT and Knowledge Engineering (ICT&KE). Bangkok, Thailand.
- [11] Arbain Sulaiman, N., & Sadli, M.D.D. (2019). An IoT-based Smart Garden with Weather Station System. 2019 IEEE 9th Symposium on Computer Applications & Industrial Electronics (ISCAIE). Malaysia.
- [12] Minwoo, R., Jaeseok, Y., Ting, M., Il-Yeup, A., Sung-Chan, C., & Jaeho, K. (2015). Design and Implementation of a Connected Farm for Smart Farming. 2015 IEEE Sensors. Busan, South Korea.
- [13] VanDerZanden, A. M. (2008). Extension page: Gardening. Oregon State University, January 2008. [Online]. Available: <https://extension.oregonstate.edu/gardening/techniques/environmental-factors-affecting-plant-growth>. [Accessed: 5 August 2019].
- [14] Dholu, M., & Ghodinde, K.A. (2018). Internet of Things (IoT) for Precision Agriculture Application. 2nd International Conference on Trends in Electronics and Informatics (ICOEI 2018). Tirunelveli, India, 2018.
- [15] Tonny, H.Y.L, Jin Wong, L., & Shu Ming, T. (2019). Wireless Blood Glucose Device with Database for Health Assessment and Monitoring. 2019 7th International Conference on Smart Computing & Communications (ICSCC). Malaysia.
- [16] Tonny, H.Y.L, Jin Wong, L., & Raymond, M. (2019). IoT Fitness Device with Real Time Health Assessment and Cloud Storage. 2019 7th International Conference on Smart Computing & Communications (ICSCC). Malaysia.
- [17] Puranik, V., Ranjan, S.A., & Kumari, A. (2019). Automation in Agriculture and IoT. 2019 4th International Conference on Internet of Things: Smart Innovation and Usages (IoT-SIU). Ghaziabad, India.
- [18] Bhadani, P., & Vashisht, V. (2019). Soil Moisture, Temperature and Humidity Measurement using Arduino. 2019 9th International Conference on Cloud Computing, Data Science & Engineering (Confluence). Noida, India.
- [19] "Learn More About ThingSpeak," [Online]. Available: [https://thingspeak.com/pages/learn\\_more](https://thingspeak.com/pages/learn_more). [Accessed: 22-Apr-2019].
- [20] "What is Blynk?" [Online]. Available: [https://subscription.packtpub.com/book/application\\_development/9781788995061/1\\_ch01lv11sec10/what-is-Blynk](https://subscription.packtpub.com/book/application_development/9781788995061/1_ch01lv11sec10/what-is-Blynk). [Accessed: 22-Apr-2019].